

# S500

# QUICK-REFERENCE

**FR-S510W-0.1K to 0.75K-NA**  
**FR-S520-0.1K to 3.7K-NA**



# Standard Specifications

1-phase 100V Class Type FR-S510W- <input type="text"/> -NA		0.1K	0.2K	0.4K	0.75K
Applicable motor capacity	kW	0.1	0.2	0.4	0.75
	HP	1/8	1/4	1/2	1
Output	Rated output capacity (kVA)	0.3	0.5	1.0	1.6
	Rated output current (A)	0.8	1.4	2.5	4.1
	Overload current capacity (% VFD continuous rating)	150% 60 seconds 200% 0.5 seconds (inverse-time characteristics)			
	Voltage	Three phase, 200V to 230V			
	Typical braking torque without DB resistor (% of motor rated FLT)	150%		100%	
Power supply	Rated input AC voltage	Single phase, 100V -10% to 115V +15%, 50Hz/60Hz			
	Max. short circuit withstand	5000A RMS			
	Est. AC input current (A)	4.5	8.2	13.6	22.7
	Recommended input fuse ampacity (UL Class K5 or equivalent)	8	15	25	40
	Inrush current limitation	Relay			
	Power supply system capacity (kVA)	0.5	0.9	1.5	.5
Enclosure	Chassis type (IP20)				
Heat Dissipated at Full Load (Watts)	16	20	45	50	
Cooling system	Self-cooling				

3-phase 200V Class Type FR-S520- <input type="text"/> -NA		0.1K	0.2K	0.4K	0.75K	1.5K	2.2K	3.7K
Applicable motor capacity	kW	0.1	0.2	0.4	0.75	1.5	2.2	3.7
	HP	1/8	1/4	1/2	1	2	3	5
Output	Rated output capacity (kVA)	0.3	0.5	1.0	1.6	2.8	4.0	6.6
	Rated output current (A)	0.8	1.4	2.5	4.1	7.0	10	16.5
	Output current (A) with 240V 1-phase input	0.4	0.8	1.5	2.5	4	5	7
	Overload current capacity (% VFD continuous rating)	150% 60 seconds 200% 0.5 seconds (inverse-time characteristics)						
	Voltage	Three phase, 200V to 240V						
	Typical braking torque without DB resistor (% of motor rated FLT)	150%		100%		50%	20%	
Power supply	Rated input AC voltage	Three phase, 200V -15% to 240V +10%, 50Hz/60Hz						
	Max. short circuit withstand	5000A RMS						
	Est. AC input current (A)	1.5	2.6	4.3	6.4	11.4	14.5	23.7
	Recommended input fuse ampacity (UL Class K5 or equivalent)	3	5	8	15	25	30	45
	Inrush current limitation	Relay						
	Power supply system capacity (kVA)	0.4	0.7	1.2	2.1	4.0	5.5	9
Enclosure	Chassis type (IP20)							
Heat Dissipated at Full Load (Watts)	16	20	45	50	85	100	160	
Cooling system	Self-cooling				Forced air cooling			

Control specifications	Control system		Algorithm	V/F control	
			Options	Soft-PWM; Adjustable carrier frequency (2kHz – 14.5kHz)	
	Output frequency range		0.2 to 120Hz (starting frequency variable between 0 and 60Hz)		
	Frequency setting resolution	Analog input		5VDC input: 0.2% of selected maximum frequency 10VDC, 4-20mADC input: 0.1% of selected maximum frequency	
		Digital input (using keypad)		< 100Hz: 0.1Hz >= 100Hz: 1Hz	
	Output frequency accuracy	Analog input		± 1% of maximum output frequency (25°C ±10°C (77°F±18°F))	
		Digital input (using keypad)		± 0.5% of commanded output frequency	
	Voltage/frequency characteristic		Base frequency setting range: 0 - 120Hz.		
	Torque Boost		Automatic Torque Boost function selectable		
	Starting torque		150% or more (at 6Hz) when automatic torque boost is selected		
	Acceleration/deceleration time setting		0, 0.1 to 999 sec (acceleration and deceleration set independently), Linear or S-pattern curves may be selected.		
	User definable input signals	Frequency setting signal	Analog input	0 to 5VDC, 0 to 10VDC, 4 to 20mADC.	
			Digital input	Entered from built-in digital setting dial	
		Start signal		Forward and reverse rotation, start signal	
		Alarm reset		Used to reset alarm output after alarm condition.	
Multi-speed selection		Up to 15 speeds can be defined			
Second function selection		Used to select second functions (acceleration time, deceleration time, torque boost, base frequency, electronic overcurrent protection).			
Output stop		Instantaneous shut-off of inverter output (frequency, voltage).			
Current input selection		Used to select input of frequency setting signal 4 to 20mADC (terminal 4).			
Thermal relay input		Used to provide interface to external thermal relay			
Digital operation-external operation switching		Used to remotely switch the VFD between operation via the digital setting dial and external operation			
3-wire control input		Control input holding circuit for 3-wire control applications			
Operation functions		Maximum/minimum frequency setting, frequency jump operation, external thermal relay input selection, automatic restart operation after instantaneous power failure, forward/reverse rotation prevention, slip compensation, operation mode selection, PID control			
Output signals	One (1) open-collector and one (1) form C contact outputs (user definable)		running, up to frequency, frequency detection, overload alarm, zero current detection, output current detection, PID upper limit, PID lower limit, PID forward/reverse rotation, operation ready, minor fault and alarm, and 1 contact output (230VAC 0.3A, 30VDC 0.3A) can be selected.		
	One (1) analog output (0 to 5 VDC, 1mA)		Output Frequency or Motor Current selectable		
Display	Control panel display	Operating status	Output voltage, output current, set frequency, running.		
		Alarm definition	Alarm definition is displayed when protective function is activated. 4 alarm definitions are stored.		
	LED display		Power application (POWER), Alarm (ALARM)		
Protective/alarm functions		Overcurrent shut-off (during acceleration, deceleration, constant speed), regenerative overvoltage shut-off, undervoltage (Note 1), instantaneous power failure (Note 1), overload shut-off (electronic overcurrent protection), stall prevention, fan overheat, fan failure (Note 4), parameter error, PU disconnection, starting-time ground fault overcurrent protection.			
Environment	Ambient temperature		-10°C to +50°C (14°F to 122°F) (non-freezing)		
	Ambient humidity		90%RH or less (non-condensing)		
	Storage temperature (Note 2)		-20°C to +65°C (-4°F to 149°F)		
	Ambience		Indoors (no corrosive and flammable gases, oil mist, dust and dirt.)		
	Altitude, vibration		Maximum 1000m (3280.80 feet) above sea level for standard operation. After that derate by 3% for every extra 500m (1640.40 feet) up to 2500m (8202.00 feet) (91%).		

- Note:
- When undervoltage or instantaneous power failure has occurred, alarm display or alarm output is not provided but the inverter itself is protected. Overcurrent, regenerative overvoltage or other protection may be activated at power restoration according to the operating status (load size, etc.)
  - Temperature applicable for a short period in transit, etc.
  - The braking torque indicated is a short-duration average torque (which varies with motor loss) when the motor alone is decelerated from 60Hz in the shortest time and is not a continuous regenerative torque. When the motor is decelerated from the frequency higher than the base frequency, the average deceleration torque will reduce. Since the inverter does not contain a brake resistor, use the optional brake resistor when regenerative energy is large. (The optional brake resistor cannot be used with 0.1K and 0.2K.) A brake unit (BU) may also be used.
  - Provided only for forced-air cooled models FR-S520-1.5K-NA, FR-S520-2.2K-NA and FR-S520-3.7K-NA

# Terminal Diagram

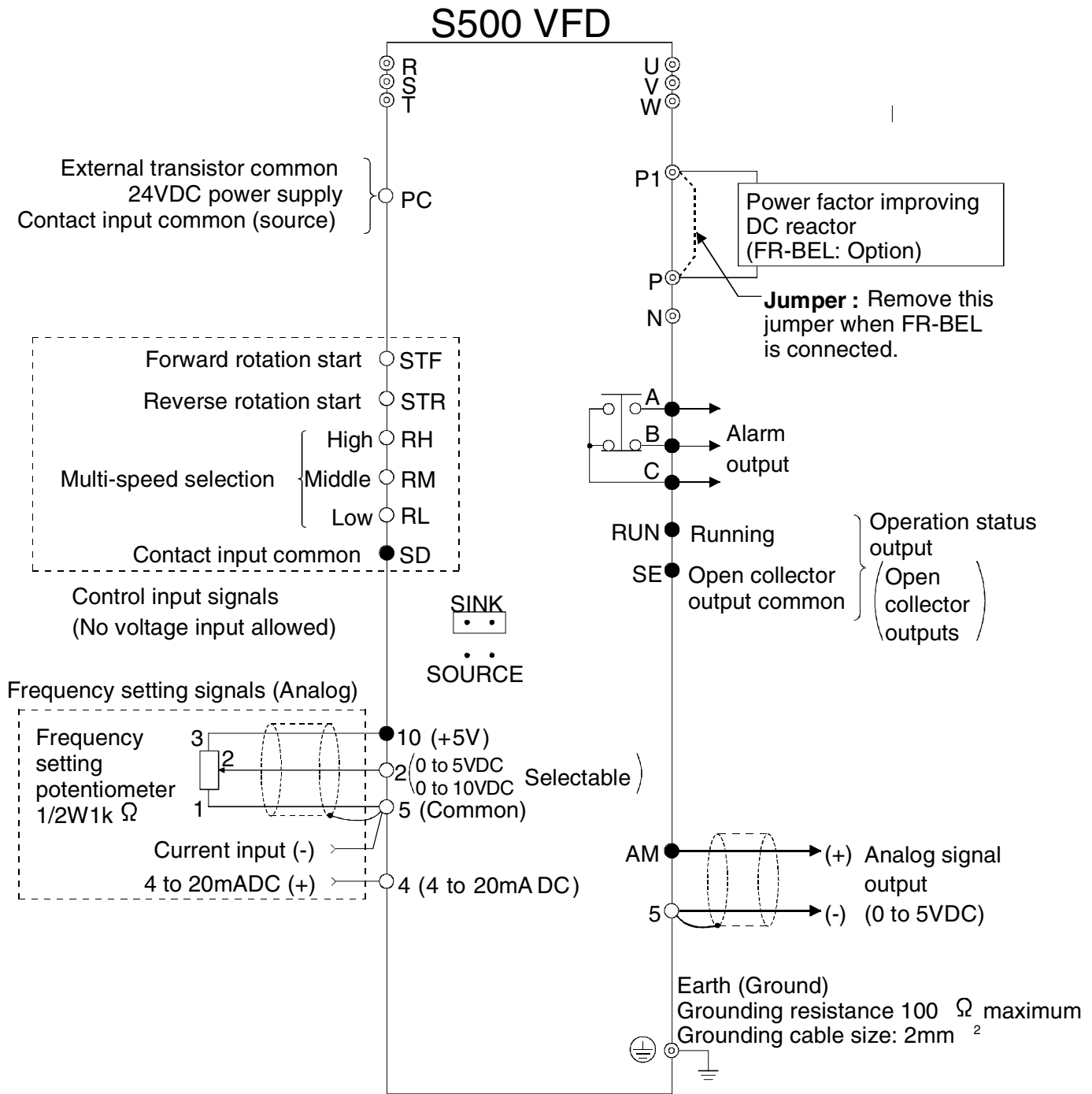

⊙ Main circuit terminal, ○ Control circuit input terminal, ● Control circuit output terminal

Symbol	Terminal Name	Description
R, S, T (L1, L2, L3)	AC power input	Connect to line power supply. NOTE: Terminals R & S are used for 1- $\phi$ input power
U, V, W	Inverter output	Connect to three-phase squirrel-cage motor.
N (-)	DC voltage common	DC voltage common terminal. Not isolated from the power supply and inverter output
P (+), P1	DC reactor connection	Connection for the optional power factor improving DC reactor.
	Ground	For grounding the inverter chassis.

Type	Symbol	Terminal Name	Description	
Input signals	Discrete	SINK/SOURCE	Sink / Source selection jumper Permits user to select sink or source type solid state logic on VFD input terminals.	
		STF	Forward rotation start Turn on the STF signal to start forward rotation and turn it off to stop.	When the STF and STR signals are turned on simultaneously, the stop command is given.
		STR	Reverse rotation start Turn on the STR signal to start reverse rotation and turn it off to stop.	
		RH, RM, RL	Multi-speed selection Combine the RH, RM and RL signals as appropriate to select multiple speeds.	Input terminal function choices (Pr. 60 to Pr. 63) change terminal functions.
		SD	Contact input common (sink*) Common for the contact input terminals when sink logic is selected. Isolated from terminals 5 & SE. Common output terminal for 24VDC 0.1A power output (PC terminal).	
		PC	Contact input common (source*) Connect the external power supply common for transistor outputs to this terminal to prevent a fault caused by leakage current. Acts as input signal common when source logic is selected This terminal may also be used as a 24VDC, 0.1A power supply when used with terminal SD	
	Analog	10	Analog speed ref. power supply	5VDC @ 10mA max
		2	Analog speed ref. (voltage)	Selectable 0 to 5VDC (factory setting) or 0 to 10VDC analog speed reference input. Input resistance 10k $\Omega$ . Maximum permissible voltage 20V.
		4	Analog speed ref. (current)	4 – 20mADC analog speed reference input. This input signal is valid only when one of the discrete input terminals is configured as "AU" and is jumpered to SD terminal. Input resistance 250 $\Omega$ . Maximum permissible current 30mA.
		5	Analog speed ref. input common	Common to the frequency setting signals (terminal 2 or 4) and the analog output (terminal AM). Isolated from terminals SD & SE Do not connect to earth.
Output signals	A, B, C	Alarm output	Form C contact output: 230VAC 0.3A, 30VDC 0.3A. Normal state (VFD power on) : A: NO; B: NC; C: Common	
	RUN	Inverter running	Closed when the VFD output frequency is equal to or higher than starting frequency. Open during stop or DC dynamic brake operation. 0.1A max @ 24VDC	
	SE	Open collector output common	Common for the RUN terminal. Isolated from terminals 5 & SD	
	AM	Analog signal output	0 to 5 VDC @ 1mA max / Output Frequency or Motor Current selectable.	

## Parameters

The parameters in the S500 VFD are extensive. To make configuration of the S500 faster and easier, the parameter set is separated logically into “Basic” and “Extended” parameters. The parameters in the Basic list only are displayed as standard and these parameters are shown below. To access the Extended parameter list, Parameter 30 must be set to 1. This reduces the number of parameters the user must scroll through to complete basic VFD configuration without limiting access to the full functionality of the VFD.

Parameter	Name	Indication	Setting Range	Minimum Setting Increments	Factory Setting <EC Version>
0	Torque boost	<i>P 0</i>	0 to 15%	0.1%	6%
1	Maximum frequency	<i>P 1</i>	0 to 120Hz	0.1Hz	60Hz <50Hz>
2	Minimum frequency	<i>P 2</i>	0 to 120Hz	0.1Hz	0Hz
3	Base frequency	<i>P 3</i>	0 to 120Hz	0.1Hz	60Hz <50Hz>
4	Multi-speed setting (high speed)	<i>P 4</i>	0 to 120Hz	0.1Hz	60Hz <50Hz>
5	Multi-speed setting (middle speed)	<i>P 5</i>	0 to 120Hz	0.1Hz	30Hz
6	Multi-speed setting (low speed)	<i>P 6</i>	0 to 120Hz	0.1Hz	10Hz
7	Acceleration time	<i>P 7</i>	0 to 999s	0.1s	5s
8	Deceleration time	<i>P 8</i>	0 to 999s	0.1s	5s
9	Electronic thermal O/L relay	<i>P 9</i>	0 to 50A	0.1A	Rated output current
30	Extended function display selection	<i>P 30</i>	0, 1	1	0
79	Operation mode selection	<i>P 79</i>	0 to 4, 7, 8	1	0

- FR-S510W-0.1K-NA, -0.2K-NA, -0.4K-NA
- FR-S520-0.1K-NA, -0.2K-NA, -0.4K-NA, -0.75K-NA

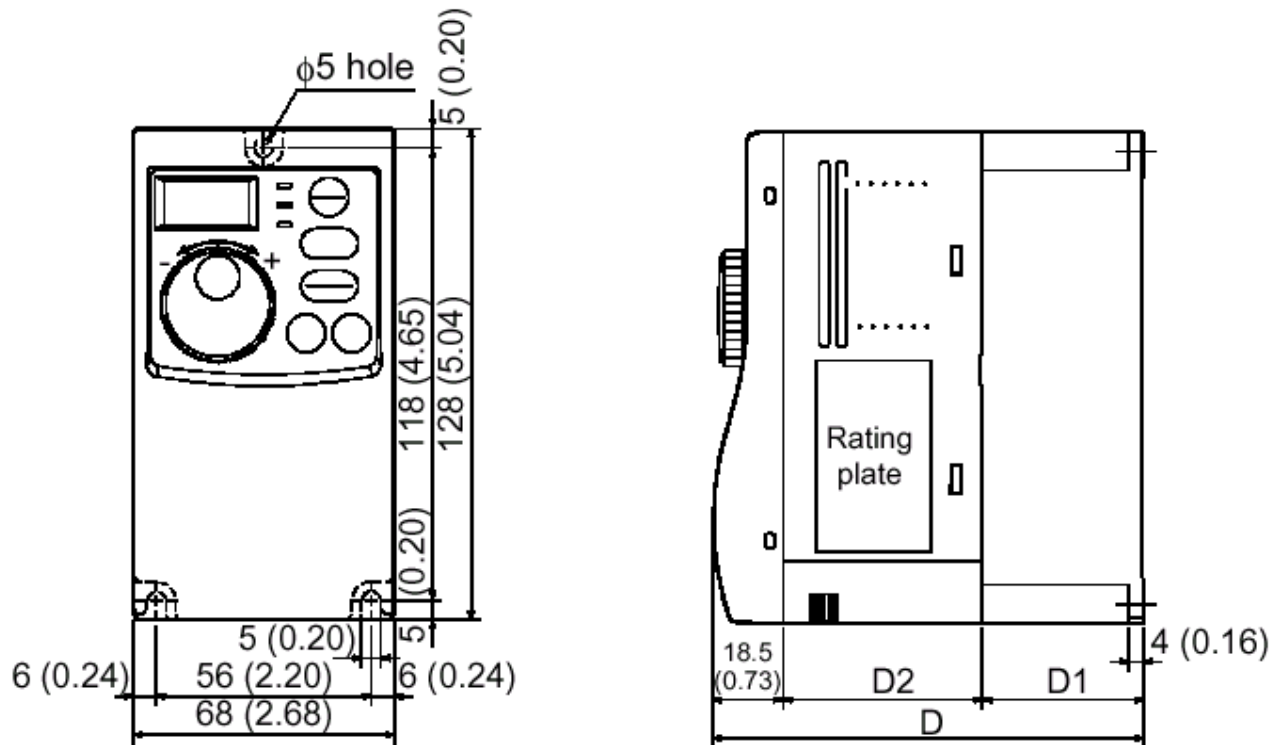

Dimensions in mm (inches)			
Inverter Model	D	D1	D2
FR-S510W-0.1K-NA	80.5 (3.17)	10 (0.39)	52 (2.05)
FR-S510W-0.2K-NA	110.5 (4.35)	40 (1.57)	52 (2.05)
FR-S510W-0.4K-NA	142.5 (5.61)	90.5 (3.56)	52 (2.05)
FR-S520-0.1K-NA	80.5 (3.17)	10 (0.39)	52 (2.05)
FR-S520-0.2K-NA	80.5 (3.17)	10 (0.39)	52 (2.05)
FR-S520-0.4K-NA	112.5 (4.43)	42 (1.65)	52 (2.05)
FR-S520-0.75K-NA	132.5 (5.22)	62 (2.44)	52 (2.05)

## Dimensions

- FR-S510W-0.75K-NA
- FR-S520-1.5K-NA, -2.2K-NA, -3.7K-NA

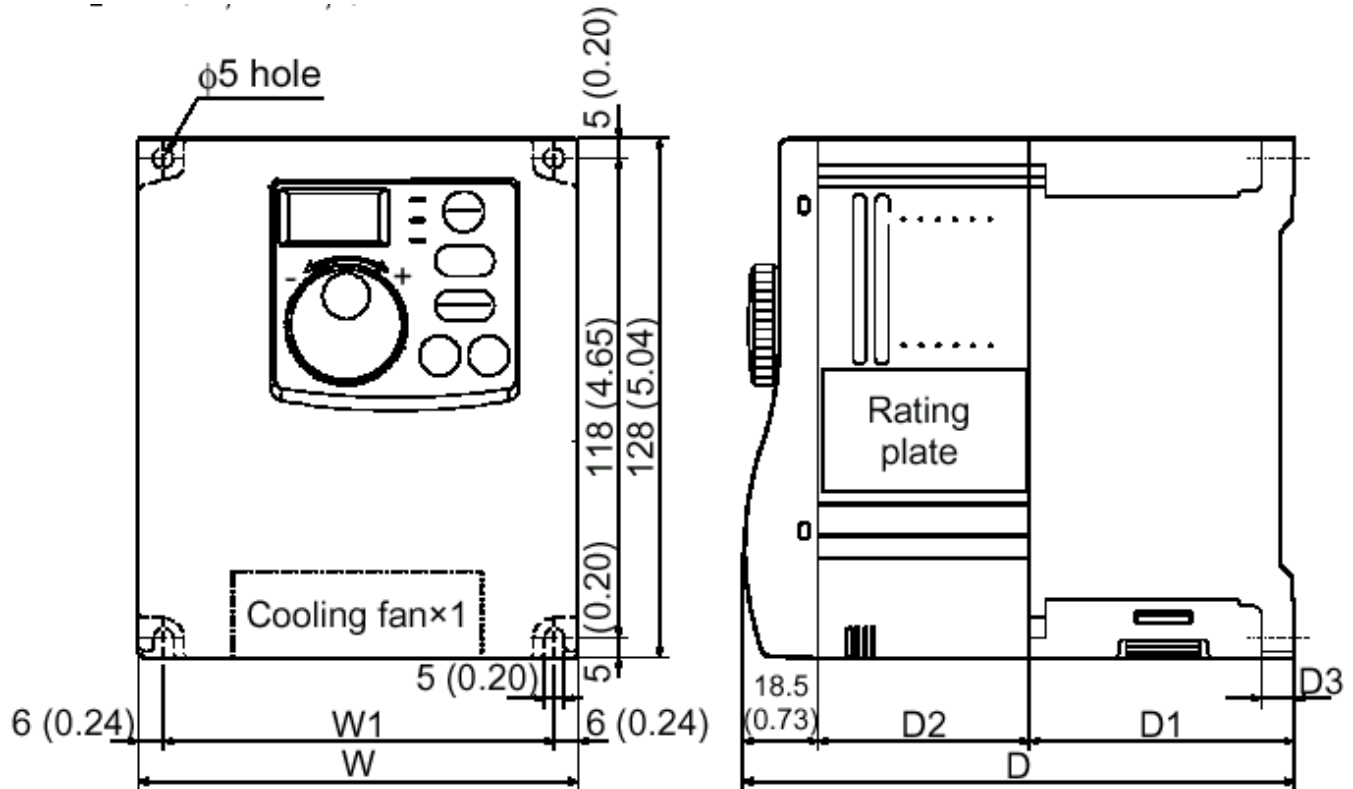

Dimensions in mm (inches)						
Inverter Model	W	W1	D	D1	D2	D3
FR-S510W-0.75K-NA	108 (4.25)	96 (3.78)	149.5 (5.89)	92 (3.62)	52 (2.05)	5 (0.20)
FR-S520-1.5K-NA	108 (4.25)	96 (3.78)	135.5 (5.33)	65 (2.56)	52 (2.05)	8 (0.31)
FR-S520-2.2K-NA	108 (4.25)	96 (3.78)	135.5 (5.33)	65 (2.56)	52 (2.05)	8 (0.31)
FR-S520-3.7K-NA	170 (6.69)	158 (6.22)	142.5 (5.61)	72 (2.83)	52 (2.05)	5 (0.20)

## EMC Filters

**S10W-NA:** 100V class filters not available.

### **S520-NA:**

Applicable VFD	EMC Filter	Mounting Adapter <sup>1</sup>	Filter Dimensions		
			H (mm)	W (mm)	D (mm)
FR-S520-0.1K – 1.5K-NA	SF1306	None Required	200	110	36
FR-S520-2.2K – 3.7K-NA	SF1309	FR-E5T	281	200	69 <sup>3</sup>

**Notes:**

1. Adapter is used to permit S520 VFD to be secured to the SF-type filters' U120 and A024 mounting hole patterns
2. Depth includes 12mm depth of FR-E5T & FR-E5T2 mounting adapters

## DIN Rail Mounting Adapters

Adapter	Applicable VFD	
FR-UDA01	Fits FR-S510W- 0.1K, 0.2K, 0.4K -NA & FR-S520-0.75K-NA	Not for mounting EMC filters
FR-UDA02	Fits FR-S510W-0.75K-NA & FR-S520- 1.5K, 2.2K -NA	
FR-UDA03	Fits FR-S520-3.7K-NA	

<b>Date</b>	<b>Revision</b>
6/30/00	First edition

This document is available only in PDF format and cannot be ordered from literature fulfilment. Please contact your Mitsubishi Electric Automation, Inc. sales office to obtain a copy.