

MITSUBISHI

TRANSISTORIZED INVERTER

-INSTRUCTION MANUAL-

DeviceNetTM Option

FR-E5ND



Thank you for choosing the Mitsubishi transistorized inverter option unit.

This instruction manual gives handling information and precautions for use of this product. Incorrect handling might cause an unexpected fault. Before using the equipment, please read this manual carefully to use it to its optimum.

Please forward this manual to the end user.

Safety Instructions

Do not attempt to install, operate, maintain or inspect this product until you have read through this instruction manual and appended documents carefully and can use the equipment correctly. Do not use this product until you have a full knowledge of the equipment, safety information and instructions.

In this manual, the safety instruction levels are classified into "WARNING" and "CAUTION".



Denotes that incorrect handling may cause hazardous conditions, resulting in death or severe injury.

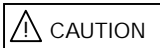

Denotes that incorrect handling may cause hazardous conditions, resulting in medium or slight injury, or may cause physical damage only.

Note that even the CAUTION level may lead to a serious consequence under some circumstances. Please follow the instructions of both levels as they are important to personnel safety.

SAFETY INSTRUCTIONS

1. Electric Shock Prevention

 **WARNING**

- While power is on or when the inverter is running, do not open the front cover. You may get an electric shock.
- Do not run the inverter with the front cover removed. Otherwise, you may access the exposed high-voltage terminals and charging part and get an electric shock.
- If power is off, do not remove the front cover except for wiring or periodic inspection. You may access the charged inverter circuits and get an electric shock.
- Before starting wiring or inspection, switch power off, wait for more than 10 minutes, and check for no residual voltage with a meter etc.
- Any person who is involved in the wiring or inspection of this equipment should be fully competent to do the work.
- Always install the option unit before wiring. Otherwise, you may get an electric shock or be injured.
- Operate the switches with dry hands to prevent an electric shock.
- Do not subject the cables to scratches, excessive stress, heavy loads or pinching. Otherwise, you may get an electric shock.

2. Injury Prevention

 **CAUTION**

- Apply only the voltage specified in the instruction manual to each terminal to prevent damage, etc.
- Ensure that the cables are connected to the correct terminals.
Otherwise, damage, etc. may occur.
- Always make sure that polarity is correct to prevent damage, etc.
- While power is on or for some time after power-off, do not touch the inverter as it is hot and you may get burnt.

3. Additional instructions

Also note the following points to prevent an accidental failure, injury, electric shock, etc.:

(1) Transportation and installation

CAUTION

- Do not install or operate the option unit if it is damaged or has parts missing.
- Do not stand or rest heavy objects on the product.
- Check that the mounting orientation is correct.
- Prevent screws, metal fragments, conductive bodies, oil or other flammable substance from entering the inverter.

(2) Test operation and adjustment

CAUTION

- Before starting operation, confirm and adjust the parameters. A failure to do so may cause some machines to make unexpected motions.

(3) Usage

WARNING

- Do not modify the equipment.

 **CAUTION**

- When parameter clear or all parameter clear is performed, each parameter returns to the factory setting. Re-set the required parameters before starting operation.
- For prevention of damage due to static electricity, touch nearby metal before touching this product to eliminate static electricity from your body.

(4) Maintenance, inspection and parts replacement

 **CAUTION**

- Do not test the equipment with a megger (measure insulation resistance).

(5) Disposal

 **CAUTION**

- Dispose of this product as general industrial waste.

(6) General instruction

All illustrations given in this manual may have been drawn with covers or safety guards removed to provide in-depth description. Before starting operation of the product, always return the covers and guards into original positions as specified and operate the equipment in accordance with the manual.

CONTENTS

1. PRE-OPERATION INSTRUCTIONS	1
1.1 Unpacking and Product Confirmation	1
1.2 Packing Confirmation	1
1.3 Structure	2
1.4 General Introduction	3
2. INSTALLATION	4
2.1 Pre-Installation Instructions	4
2.2 Installation Procedure	5
2.3 Pre Network Connection Procedure	7
2.4 Connection to Network	9
2.5 Changing Node Addresses	10
2.6 LED Status Indicator	11
3. GETTING STARTED	13
3.1 Introduction	13
3.2 Basic Configuration	14
3.3 Loss of Communications	15
4. OPERATION	17
4.1 Operation Modes	17
4.2 Operation Mode Selection	18

4.3	Functions Available in Operation Modes	19
4.4	Input from DeviceNet to inverter	20
4.5	Output from Inverter to DeviceNet	21
4.6	Operation on Alarm Occurrence	22
4.7	Inverter Reset	23
4.8	Setting Frequency (f) Value	23
4.9	Parameter Clear (Pr Clr) Commands	23
4.10	Control Input Commands	23

5. FR-E5ND SPECIFIC PARAMETERS	24
---------------------------------------	-----------

5.1	Pr. 345 to Pr. 348	24
5.2	Other Option-Specific Parameters	27

6. OBJECT MAP	29
----------------------	-----------

6.1	Class 0x01 - Identity Object	29
6.2	Class 0x03 - DeviceNet Object	30
6.3	Class 0x04 - Assembly Object	31
6.4	Class 0x05 - DeviceNet Connection Object	41
6.5	Class 0x28 - Motor Data Object	48
6.6	Class 0x29 - Control Supervisor Object	49
6.7	Class 0x2A - AC Drive Object	50
6.8	Class 0x66 - E500 Extended Object I	53

6.9 Class 0x67 - E500 Extended Object II	60
6.10 Response Timing	62
6.11 Recommendation For Software Developers	63

7. E500 PARAMETERS	64
---------------------------	-----------

8. TROUBLESHOOTING	73
---------------------------	-----------

8.1 Inspecting the Display On Parameter Unit and LED2 (MNS) Status LED On the E5ND	73
--	----

9. SPECIFICATIONS	74
--------------------------	-----------

Appendix 1 Electronic Data Sheet	75
---	-----------

-MEMO-

1. PRE-OPERATION INSTRUCTIONS

1.1 Unpacking and Product Confirmation

Take the option unit out of the package, check the unit name, and confirm that the product is as you ordered and intact.

1.2 Packing Confirmation

Make sure that the package includes the following accessories:

- Instruction manual 1
- Mounting screws M3 × 6 2
- Seal..... 1

1.3 Structure

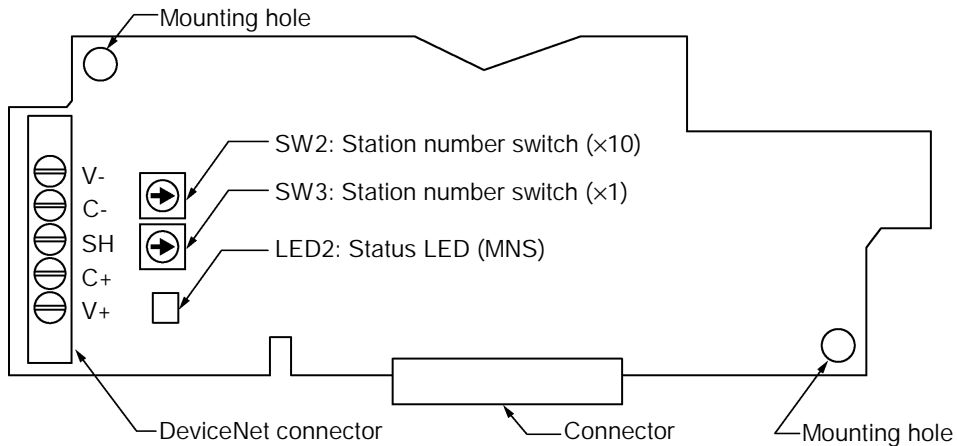

1.4 General introduction

1.4.1 General

The purpose of this manual is to provide general information, installation, and operation procedures for the FR-E5ND DeviceNet option, used with the FR-E520S-EC/CH and the FR-E540 (all versions) series inverters.

Read this manual completely before installing, operating or servicing the option unit.

This manual is intended for use by qualified personnel.

Installation should only be performed by qualified personnel. You must be able to operate and program serial devices to use the equipment.

This option allows the inverter to be connected to a network adhering to the DeviceNet communications protocol.

Illustrations provided in this manual may have covers or safety guards re-moved to provide a clear view. Before starting operation of the product be sure to install covers and guards into the original position.

The following is a list of important features of the option unit

- Data Rates of 125K baud, 250K baud, and 500K baud.
- Up to 64 stations supported on a single network
- Ability to add or remove stations without disrupting network operation.
- Network access to all inverter parameters, Start/Stop commands, and monitor data.

1.4.2 Description

The FR-E5ND option unit consists of a single circuit board as shown in section 1.3.

The option unit is mounted into the option slot of the inverter. Two station switches allow the assigning of station numbers from 0 to 63 (SW2 and SW3). An LED status light (LED2) mounted next to the DeviceNet connector provides status information on the communication link.

2. INSTALLATION

INSTALLATION

Installation requires the removal of the inverter cover. The inverter top cover must be removed to install the option unit. After installation, the top cover should be reinstalled and connection to the DeviceNet bus is completed through a connector accessible through the lower connector port on the inverter unit.

WARNING

 Cover removal can expose charged components. Be sure the proper procedures are followed when removing the cover.

Remove cover following the procedure in the inverter manual.

2.1 Pre-Installation checks

Verify that the following included components are supplied	<ol style="list-style-type: none">1. FR-E5ND option unit2. Two mounting screws M3 x 63. Instruction manual
Verify the inverter type	This option unit is designed to work with the FR-E520S-EC/CH series and FR-E540 (all versions) series inverters. Do not attempt to use this option unit with any other inverter models. These models use a different connector and if the user forces the connector the inverter may be damaged.
Ensure that the inverter input power is turned off	The inverter and/or the option unit may be damaged if installed with power on. The inverter performs an initialization procedure at power on which includes checking the option port. Adding the option later will cause a hardware conflict, resulting in an option error. Also, this may damage the inverter or the option unit.

2.2 Installation Procedure

Mounting Option Unit In Inverter Option Slot.

1. Verify that power has been turned off and that the inverter top cover has been removed.
2. Using the two mounting holes for alignment reference, carefully insert the option unit connector into the inverter connector and firmly push the unit into place.

NOTE: If screw holes in option unit do not line up with the inverter mounting holes, check that the connector has been correctly fitted.

3. Secure the option unit to the inverter with the two mounting screws.
4. The option unit is now mechanically installed.

Constructing DeviceNet Drop Cable

A DeviceNet drop cable (see the following diagram) is used to connect the FR-E5ND option unit to the DeviceNet network. The drop cable consists of an ODVA approved "Thin" cable as well as an ODVA approved 5-pin connector that mates with the FR-E5ND DeviceNet option connector. Another connector compatible with the network trunk cable must also be selected by the user/installer.

NOTE: Only "Thin" type cable should be used.

Recommended parts are:

DeviceNet Thin Cable: Belden part number 3084A or equivalent.

5-Pin Connector for FR-E5ND: Phoenix Contact part number MVSTBW2.5/5-ST-5.08-AU.

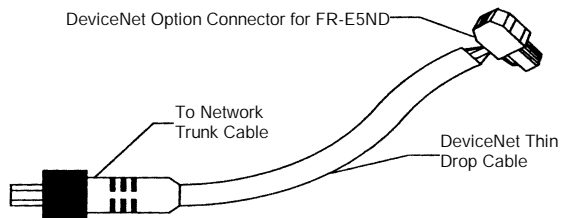

The DeviceNet option connector pin out connections are shown in the below diagram.
The function for each pin is listed in the below table.

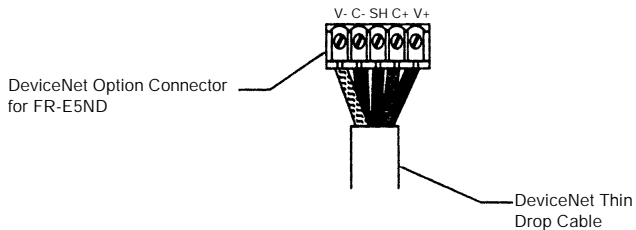

Pin No.	Terminal name	Color	Signal name
1	V-	Black	V-
2	C-	Blue	CAN-
3	SH	Bare	Shield
4	C+	White	CAN+
5	V+	Red	V+

1. Strip the insulation and shielding back 3.5 to 4cm (approximately 1.5 inches) on the free wire end of the drop cable to expose the four colored signal wires and the silver shield wire.
2. Strip the insulation back about 6 mm (0.25 inches) on the signal wires.
3. Tin the end of the shield wire to prevent it from fraying if necessary.
4. Attach the connector to the DeviceNet cable as follows:
 - a. Using a flathead screwdriver (3.75 mm maximum width), insert the screwdriver into the upper holes of the connector plug (as shown in the previous diagram) to open the clamps in the lower holes to allow wires to be inserted.
 - b. Install the signal wires into the Phoenix contact connector plug as shown in the previous diagram. Be sure to match the wire colors to the correct pins as shown in the previous table.
 - c. After all wires are properly inserted, turn the holding screws (as shown in the previous diagram) clockwise to securely clamp the wires. When properly tightened the wires should not be able to be pulled out.

2.3 Pre Network Connection Procedure

NOTE: Each Device on the network must be assigned a unique station number between the values of 0 to 63

1. Set the two Station number switches (these are shown in the diagram in Section 1.3) for a address between 0 and 63. Any number out of the range of 0 to 63 is automatically changed to 63 by the option unit software.

2. Be sure that the FR-E5ND option unit is correctly inserted into the inverter and the option unit connector is fully and firmly in position before proceeding.
3. Remove the option data port insert (see the following diagram) from the inverter cover.
4. Reinstall the inverter cover making sure that option data port opening is aligned with the DeviceNet connector.
5. Connect the DeviceNet thin drop cable to the inverter by inserting the 5-pin connector through the data port opening, into the DeviceNet standard socket on the option unit.

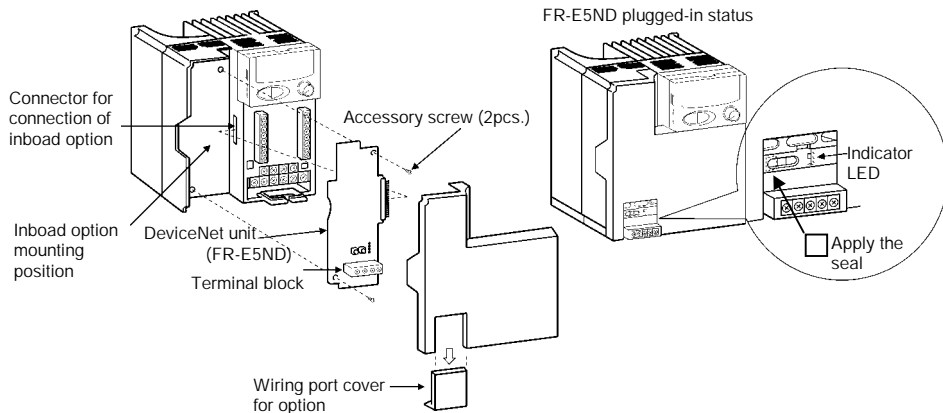

2.4 Connection to Network

At this point the option unit should be installed in the inverter, the address switches properly set, the cable constructed and the connector connected to the option unit through the option data port.

CAUTION

 Do not connect cable to the network until told to do so.

1. Check that the inverter power is off.
2. Make sure that a terminating resistor is installed across each end (CAN(+) and CAN(-)) of the trunk cable, as shown in the following diagram.

These resistors must meet the following requirements:

- a) R = 121 ohms
 - b) 1 % metal film
 - c) 0.25 Watts
3. Connect the cable to the network as follows:
 - a) If the trunk connector is a DeviceNet sanctioned pluggable or sealed connector, the connection to the active network can be made at any time whether inverter is on or off. The option unit automatically detects when the connection is completed.
 - b) If connecting to the network with free wires, power to the network and inverter should be shut off as a safety precaution in case two or more signal wires are accidentally shorted together.
 4. Check that all connections are completed and all necessary wires not associated with DeviceNet are connected to the inverter unit as needed.
 5. It is now safe to apply power to the inverter and run it in the PU or external mode.

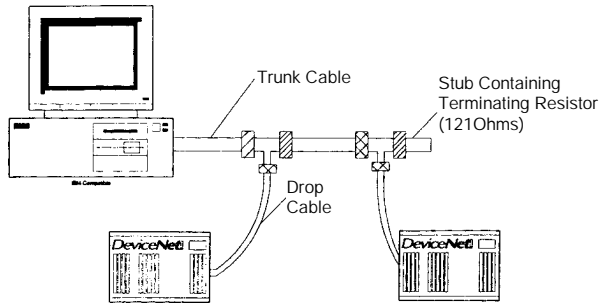

2.5 Changing Node Addresses

NOTE: The state of the address switches is sampled once at power on.

Changing the address later on will have no effect and the software will keep the number read at power on. To change the address switches follow the below procedure:

1. Turn power off.
2. Disconnect drop cable from option unit.
3. Remove inverter cover.
4. Set address switches for desired address. (SW2 is the 10 times setting, SW3 is the 1 times setting.)

5. Reinstall inverter cover.
6. Reconnect drop cable to inverter option unit.
7. Turn power on.

NOTE: Do not set the Node address (station number) to 64 or greater.

2.6 LED Status Indicator

The LED Status indicator labeled LED2 (MNS) (see Section 1.3) provides information on the status of operation as shown in the following table. The indicator has five states, Off, Blinking Green, Steady Green, Blinking Red, and Steady Red. After connecting the drop cable to the trunk of the active network, observe the condition of the Status LED (LED2 (MNS)). The option unit uses the Combined Module/Network status LED scheme described in the DeviceNet communications standard.

STATUS LED (LED2 (MNS)) CONDITION	STATE OF SYSTEM	NOTE
Off	Inverter power off Network and inverter power on	Turn inverter power on, the option unit will then complete a duplicate station number test.
Blinking Green	Network and inverter power on Connection not yet established by host	The option unit has powered up successfully and determined that its station number does not conflict with other stations. However, a host has not yet established a communications link.
Steady Green	Network and inverter power on Connection established by host	A master device on the Network has designated the device for communications. The LED holds this state also during communications.

STATUS LED (LED2 (MNS)) CONDITION	STATE OF SYSTEM	NOTE
Blinking Red	Connection time out	Master designated option unit for communication (LED green state), but then sent no messages within the time limit set in the expected packet rate (note 1). Check to see that the host station has not been disconnected from the network.
Steady Red	Critical link failure	Failed communication device: <ul style="list-style-type: none">● Duplicate station number● Network power off● Cable from option unit to network not connected or severed● Network damaged Must cycle power to recover this fault.

Note 1: Time limit = 4 x EPR (Expected Packet Rate). This is the EPR as set in the master controller.

3.1 Introduction

This section is intended to facilitate the configuration of the FR-E5ND DeviceNet option with minimum effort. It is assumed that the default values specified in this section are acceptable to the user. If the user wishes to change these values, the data necessary to do so is provided later in the manual.

This section assumes that network cabling is complete and DeviceNet communication has been established. The status LED (LED2 (MNS)) on the FR-E5ND option should be either blinking green or steady green as described in the table in section 2.6.

3.1.1 General Description

The FR-E5ND DeviceNet option unit is considered a slave device in the DeviceNet communication standard. This means that the FR-E5ND cannot initiate messages on the network. A master device must establish a connection to the option unit and then send commands, requests for information, etc. **Note:** When the master station is set-up and turned on, the inverter unit may need up to 1 minute to get set to a ready for communication status. This is a situation may occur for just the DeviceNet configuration stage, so this should not be a general problem.

The FR-E5ND option unit supports Group 3 Messaging as defined in the DeviceNet standard. This feature of the FR-E5ND option unit means that it is possible for one master to control the inverter while another reads data from the same inverter. This also means that the DeviceNet master must support the UCMM protocol for proper operation.

It is strongly recommended that the user configures the DeviceNet network using a software tool designed specifically for that purpose. The use of such a tool greatly simplifies the configuration, reduces confusion, and enhances accuracy. Additionally, the configuration tool will facilitate the elimination of conflicts between network devices and ensure consistency throughout the network.

One such tool is DeviceNetManager™ as supplied by Rockwell Automation.

Tools are available from many other suppliers but the descriptions contained in the “Getting Started” section are based upon the use of DeviceNetManager™.

When adding the FR-E5ND DeviceNet Option Unit to a FR-E520S-EC/CH or FR-E540 (all versions) series inverters that have previously been configured for a specific application, it may be necessary to complete a "Parameter All Clear" (PrClr) instruction in the inverter in order to remove unintentional conflicts and to allow the inverter to recognize the presence of the option card.

If this becomes necessary, you will need to record the existing configuration before issuing the PrClr command as this command will restore factory default values to all inverter parameters. Once the command is completed and the inverter has recognized the FR-E5ND option unit, the inverter configuration data may be re-entered either via the parameter unit or the network.

To use the DeviceNetManager™ software, you will need to acquire the DeviceNet Electronic Data Sheet (EDS) file. The EDS file is a standard DeviceNet file which defines the configurable parameters of a field device and facilitates the network configuration softwares ability to recognize a specific field device. Please refer to the configuration software tool instruction manual for more information about the installation and use of EDS files.

Refer to Appendix 1 for details on this file.

3.2 Basic Configuration

3.2.1 Setting the Baud Rate:

The baud rate must be consistent throughout the network in order to establish communication and allow configuration via the network. Therefore, this step is critical to the success of the FR-E5ND option units configuration.

Upon power-up, the FR-E5ND DeviceNet option unit will default to a communication speed of 125 Kbps.

The baud rate may be set via the network using "Baud Rate", attribute 2 of DeviceNet Class 0x03, instance 1. See section 6.2.3 for further information.

The baud rate may be set manually via the parameter unit by changing Pr. 346 and Pr. 348. See section 5.1 for further information.

Set Node Address: The station number assigned to the FR-E5ND option unit in section 2.3 will determine the default node address upon inverter power-up. If, upon network configuration, an address conflict is found, the Node Address may be set by using "Node Address", attribute 1 of the DeviceNet Class 0x03, instance 1. See section 6.2.3 for further information.

3.2.2 DeviceNet I/O Assembly:

Communication between a master device and a slave device on the network requires that the DeviceNet Class 0x04 – "Assembly Object" in both devices be the same.

3.2.2.1 Default I/O Assembly:

Upon power-up, the FR-E5ND option unit will default to Class 0x04 – Output Instance 21 and Class 0x04 – Input Instance 71. See Section 6.3 for further information on DeviceNet Class 0x04 and changing the desired Output and Input Instances.

3.2.2.2 Polling Rate:

Determination of the proper polling rate of the DeviceNet master device is dependent upon the characteristics of the entire network. To minimize potential conflicts and maximize system reliability, a minimum polling rate interval of 30ms is suggested. The user may, at their discretion, adjust this rate as network performance allows.

3.3 Loss of Communications

In the default polled communication mode, the FR-E5ND DeviceNet option unit will respond to loss of polling based upon configuration of the EPR (Expected Packet Rate) bits of parameter 345 and 347 (Pr. 345 and Pr. 347) as defined in Section 5.1 of this manual. The default value of these bits is decimal 0. Such loss of polling may occur upon physical disconnection of network cabling, network power loss, failure within the master, etc.

When the EPR bits of Pr. 345 and Pr. 347 are set to decimal 0, the inverter will continue to execute the last command received until the communication time-out is reached. This time out value is equal to 4 times the Expected Packet Rate (EPR) as configured by the user (this is set in the master controller). Once the FR-E5ND times out, the inverter will generate an E.OPT error and coast (free-run) to a stop.

When the EPR bits of Pr. 345 and Pr. 347 are set to decimal 2, the inverter will continue to execute the last command received until another command is issued. The FR-E5ND will ignore the communication loss, generate no error and automatically reset the connection when communication is restored.

4. OPERATION

Operation of the FR-E520S-EC/CH and FR-E540 (all versions) changes slightly when the FR-E5ND option is installed. These changes are described in the following paragraphs. Parameter definitions including newly created parameters, as well as operation with the FR-E5ND installed are described.

4.1 Operation Modes

4.1.1 PU operation mode

Control of the inverter is from the parameter unit (PU).

4.1.2 External operation mode

Control of the inverter is by external signals connected to the inverters control terminal block.

4.1.3 Network operation mode

Control of the inverter is via commands from a DeviceNet master. However, FR-E5ND-specific parameters (Pr. 338 and Pr. 339) can be used to select external control for forward/reverse/stop and output frequency setting.

4.2 Operation Mode Selection

The following chart describes the required actions to change the operation mode.

Mode change	Required action
External operation → PU operation	Press the MODE key on the control panel and use the UP and DOWN arrow keys to change to the PU operation mode. For further details please refer to the relevant E500 series inverter manual.
PU operation → External operation	Press the MODE key on the control panel and use the UP and DOWN arrow keys to change to the External operation mode. For further details please refer to the relevant E500 series inverter manual.
External operation → Network operation	DeviceNet connection is allocated.
Network operation → External operation	All DeviceNet connections are released.

For all other mode changes, please consult the FR-E520S-EC/CH and FR-E540 (all versions) Instruction Manual.

The following conditions must also be met before a mode change can be effected:

- Inverter is stopped
- Forward and reverse commands are off

Parameter 340 (Pr. 340) allows selection of network operation mode on power up and after an inverter reset.

4.3 Functions Available in Operation Modes

The functions of the drive depend on the mode of the inverter. The following chart indicates the available commands according to the inverter operation mode.

Control type	Command type	Operation mode		
		Net mode	External mode	PU mode
DeviceNet	Operation command	Yes (note 1)	No	No
	Output freq. setting	Yes (note 1)	No	No
	Monitor	Yes	Yes	Yes
	Parameter write	Yes (note 3) (while stopped)	No (note 3)	No (note 3)
	Parameter read	Yes	Yes	Yes
	Inverter reset	Yes (note 2)	No	No
External terminals	Operation command	Yes (note 1)	Yes	No
	Output freq. setting	Yes (note 1)	Yes	No
	Inverter reset	Yes	Yes	Yes

Note 1: Depends on value of Pr. 338 and Pr. 339

Note 2: The Inverter cannot be reset if computer link communication error has occurred

Note 3: As set in Pr. 77

4.4 Input from DeviceNet to Inverter

4.4.1 Control Input Commands

FR-E5ND supports STF and STR. Some other Control Input Commands are also supported.

4.4.2 Output Frequency Setting

Output frequency setting is possible for the range 0 to 400 Hz in increments of 0.01 Hz.

4.4.3 Inverter Reset

The inverter can be reset via DeviceNet using Identity Object reset service. Note that this reset service also performs a parameter clear, the type of which depends on the type of the Identity Object reset service. See Sections 6.1.4, 6.6.3 and 6.7.3 for relevant implementations.

4.4.4 Parameter Writing

For parameter writing, all standard parameters are supported. In addition, the parameters listed in the Option-specific Parameter section of this specification are supported.

4.5 Output from Inverter to DeviceNet

4.5.1 Inverter Status

Inverter status can be monitored using class 0x2A, attribute 114, the FR-E520S/FR-E540 inverter status. This is a bit-mapped status byte defined as follows:

Bit	Definition	
0	Running	(RUN)
1	Forward running	(FWD)
2	Reverse running	(REV)
3	Up to frequency	(SU)
4	Overload	(OL)
5	-	-
6	Frequency detection	(FU)
7	Alarm	-

4.5.2 Inverter Monitoring

The following items can be monitored:

- Output frequency
- Output current
- Output voltage

4.5.3 Parameter Read

For parameter reading all standard parameters are supported, also specific type related parameters are also supported. Some inverter parameters require configuration to be viewed via the PU. All supported parameters are fully accessible regardless of inverter configuration in such cases.

4.6 Operation on Alarm Occurrence

The following table shows the behavior of inverter and network communication operation on alarm occurrence.

Type of fault	Item	Operation mode		
		Net mode	EXTernal mode	PU mode
Inverter (note 3)	Inverter operation	Stop	Stop	Stop
	Network communication	Continue	Continue	Continue
DeviceNet communication (note 4)	Inverter operation	Stop (note 1)	Continue	Continue
	Network communication	Continue (note 2)	Continue (note 2)	Continue (note 2)

Note 1: Inverter operation stops if the FR-E5ND signals an option error to the inverter on expiration of the Inactivity/Watchdog timer of the connection object.

Note 2: Depends upon the type of communication fault.

Note 3: Example, E.OPT

Note 4: Examples, blinking red LED, red LED.

Please refer to Section 8, Troubleshooting in this manual and the Protective Functions section of the FR-E520S-EC/CH and FR-E540 manuals respectively for more details.

4.7 Inverter Reset

Inverter reset behavior is as noted in Section 4.4.3.

4.8 Setting Frequency (f) Value

To change frequency setting value in RAM, access it by Attr.# 112 and #113 of Class 0x2A AC Drive Object. Please refer to Section 6.7.3.

4.9 Parameter Clear (Pr Clr) Commands

To access various Pr. Clr Commands, use Attr. # 102 to # 106 Of Class 0x2A AC Drive Object.

4.10 Control Input Commands

To send any Control Input Command to the inverter, use Attr.#114 of Class 0x2A AC Drive Object supplied with the desired Command Data. For example, setting it with value 0x0002 will cause the inverter to run FWD at frequency value set in RAM.

Refer to the following bitmap tables for details:

7	6	5	4	3	2	1	0
0	0	RL	RM	RH	STF	STR	0

15	14	13	12	11	10	9	8
0	0	0	0	0	MRS	0	0

5. FR-E5ND SPECIFIC PARAMETERS

FR-E5ND SPECIFIC PARAMETERS

There are several parameters which are used only when the FR-E5ND is installed in the FR-E520S-EC/CH or FR-ES40 inverter. The following sections describe these parameters.

5.1 Pr. 345 to Pr. 348

Pr. No.	Function	Setting range	Minimum increment	Default setting
345	DeviceNet address start-up data (Lower byte)	0 to 255	1	63 (0x3F)
346	DeviceNet Baudrate start-up data (Lower byte)	0 to 255	1	132 (0x84)
347	DeviceNet address start-up data (Higher byte)	0 to 255	1	160 (0xA0)
348	DeviceNet Baudrate start-up data (Higher byte)	0 to 255	1	80 (0x50)

To support the FR-E5ND, 4 new parameters were created, Pr. 345, Pr. 346, Pr. 347 and Pr. 348.

The PU displays only in decimal integers. The hexadecimal integers in the parentheses are used here for easy bitmap reference only.

Pr. 345 and Pr. 347 are bit-mapped parameters. Their definition is as follows.

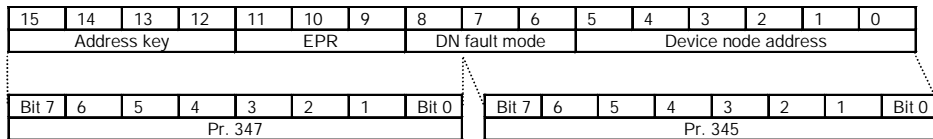

FR-E5ND SPECIFIC PARAMETERS

Pr. 346 and Pr. 348 are bit-mapped parameters. Their definition is as follows.

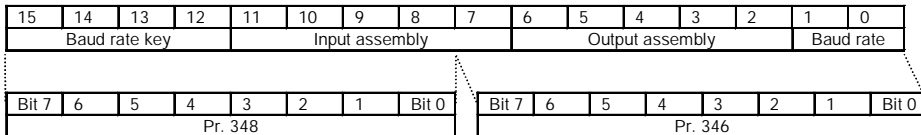

Definitions of each registration.

Name	Description	Definition	Default Value
Watch dog timeout operation (EPR)	DeviceNet connection object (Class code 0x05) Instance 2 attribute 12	0 = Transition to timeout 1 = Automatic delete 2 = Automatic reset	0
DN fault mode	Supports the control management object. (Class code 0x29) Instance attribute 16, DN fault mode	0 = Fault + stop 1 = Ignore	0
Input assembly	Value of assembly ID used in connection object. (Class code 0x05) Instance attribute 16, consumed_connection_path	Assembly ID 0 = 0x46 1 = 0x47 6 = 76 8 = 150	1

FR-E5ND SPECIFIC PARAMETERS

Name	Description	Definition	Default Value
Output assembly	Assembly ID value used in connection object. (Class code 0x05) Instance attribute 14, produced_connection_path	Assembly instance ID 0 = 0x14 1 = 0x15 6 = 26 8 = 100	1
Baud rate	DeviceNet object value (Class code 0x03) Instance attribute 2, baud rate	0 = 125 kbps 1 = 250 kbps 2 = 500 kbps	0
Device address	DeviceNet object value (Class 0x03) Instance attribute 1, MAC ID	Node address; Range is 0 to 63 (same definition as attribute)	63
Address key	Internal confirmation	1010-setting value; No others	1010
Baud rate key	Internal confirmation	1010-setting value; No others	0101

Normally, these parameters will not be accessed via the PU. Instead, a DeviceNet user will access the various fields of these parameters via DeviceNet and set them according to the table above.

5.2 Other Option-Specific Parameters

The following table identifies option-specific parameters which are used for the E5ND. The definition for Pr. 340 is identical to the definitions for use with the previous Mitsubishi communications option unit FR-EPB for FR-A200E.

Pr. No.	Function	Setting Range	Minimum Increment	Default Setting
338	Operation control command source	0, 1	1	0
339	Speed command source	0, 1	1	0
340	Link start-up mode selection	0, 1	1	0
342	Setting of EEPROM write by FR-E5ND	0, 1	1	0

Control Source Selection		Functions										
Pr. 338 (Control)	Pr. 339 (Speed ref.)	STF	STR	STOP	RT	2	4	RH, RM, RL	AU	RES	MRS	OH
0 (DeviceNet)	0 (DeviceNet)	DN	DN	-	-	DN	-	-	-	Both	Ext	Ext
0 (DeviceNet)	1 (External terminal)	DN	DN	-	-	Ext	Ext	Ext	Ext	Both	Ext	Ext
1 (External terminal)	0 (DeviceNet)	Ext	Ext	Ext	Ext	DN	-	-	-	Both	Ext	Ext
1 (External terminal)	1 (External terminal)	Ext	Ext	Ext	Ext	Ext	Ext	Ext	Ext	Both	Ext	Ext

Below is the definition for Pr. 338 and Pr. 339.

Note: Ext - Control is via input to external terminal

DN - Control is via DeviceNet

Both - Control is via either external terminals or DeviceNet

'-' - Control is via neither external terminals nor DeviceNet

Aux - Control is via input to external terminal when Pr. 28 (multi-speed input compensation) is 1

Definition of Pr. 340:

Value	Function
0	The inverter always goes to Ext-mode after power-up or Inverter reset.
1	The inverter always goes to Net-mode after power-up or Inverter reset.

6. OBJECT MAP

This section describes the object definitions for the FR-E5ND DeviceNet implementation. For details of the definitions, please consult the DeviceNet documentation available from ODVA.

6.1 Class 0x01 - Identity Object

6.1.1 Class 0x01 Attributes - Instance 0

#	Access	Attribute	Type	Value
1	Get	Revision	Word	1
2	Get	Maximum Instance	Word	1
6	Get	Maximum Class Attributes	Word	7
7	Get	Maximum Instance Attributes	Word	7

6.1.2 Class 0x01 Services - Instance 0

#	Service
0x0E	Get Attribute Single

6.1.3 Class 0x01 Instance Attributes - Instance 1

#	Access	Attribute	Type	Value
1	Get	Vendor ID	Word	82 (0x52)
2	Get	Product Type	Word	0x0002
3	Get	Product Code	Word	500
4	Get	Revision	Word	0x0101
5	Get	Status	Word	0x0000
6	Get	Serial Number	Word	xxxx
7	Get	Name	Word	"E500"

6.1.4 Class 0x01 Instance Services - Instance 1

#	Service	Description
0x05	Reset	0 - Inverter Reset 1 - Pr. All clear and Inverter Reset
0x0E	Get Attribute Single	

6.2 Class 0x03 - DeviceNet Object

6.2.1 Class 0x03 Attributes - Instance 0

None. Not Applicable, not related to E500.

6.2.2 Class 0x03 Services - Instance 0

None. Not Applicable, not related to E500.

6.2.3 Class 0x03 Instance Attributes - Instance 1

#	Access	Attribute	Value
1	Get/Set	Node Address*	0 to 63
2	Get/Set	Baud Rate*	0 to 2
3	Get/Set	Bus Off Interrupt	0 to 1
4	Get/Set	Bus Off Counter	0 to 255
5	Get	Allocation Information	0 to 0xFFFF
8	Get	MAC ID Switch Value	0 to 63

* See also Class 0x67, Attrs. 45 and 46.

6.2.4 Class 0x03 Instance Services - Instance 1

#	Service
0x4B	Allocate
0x4C	Release
0x0E	Get Attribute Single
0x10	Set Attribute Single

6.3 Class 0x04 - Assembly Object

6.3.1 Class 0x04 - Output Instance 20

Instance 20 0x14	Byte	Bit 7	Bit 6	Bit 5	Bit 4	Bit 3	Bit 2	Bit 1	Bit 0
	0						Fault Reset		Run Fwd
	1								
	2	Speed Reference (Low Byte)							
	3	Speed Reference (High Byte)							

6.3.2 Class 0x04 - Output Instance 21 (Default)

Instance 21 0x15	Byte	Bit 7	Bit 6	Bit 5	Bit 4	Bit 3	Bit 2	Bit 1	Bit 0
	0		Net Ref	NetCtrl			Fault Reset	Run Rev	Run Fwd
	1								
	2	Speed Reference (Low Byte)							
	3	Speed Reference (High Byte)							

6.3.3 Class 0x04 - Output Instance 26

Instance	Byte	Bit 7	Bit 6	Bit 5	Bit 4	Bit 3	Bit 2	Bit 1	Bit 0
26 0x1A	0	Write Param	Net Ref	NetCtrl			Fault Reset	Run Rev	Run Fwd
	1	00							
	2	Speed Ref or Parameter Write Data (Low Byte)							
	3	Speed Ref or Parameter Write Data (High Byte)							
	4	Parameter Class							
	5	Parameter Attribute Number							

Output Instance 26 (0x1A) provides write/read parameter access control of the parameter class, the parameter attribute number, and the parameter data for a write operation.

Output Instance 26 must be used together with Input Instance 76 in those applications requiring parameter access.

Output Instance 26 utilizes 6 data bytes.

The Output Instance 26 bytes operates in the following manner:

BYTE 0:

Bit 7 - If Write parameter = 1, the Parameter Write Data is written to the parameter and the rest of the parameter is ignored.

Bit 7 - If Write Parameter = 0, the Speed Ref in RPM is set, and the rest of the command byte is executed.

Bit 6 - If NetRef = 1, the Speed Ref is taken from BYTE 2 and BYTE 3.

Bit 5 - If NetControl = 0, the Speed Ref from the result of the AC Drive parameter settings.

Bit 4 - Not Used.

Bit 3 - Not Used.

Bit 2 - If Fault Reset makes a transition from 0 to 1 and there is an error in the inverter, the inverter will reset.

Bit 1 - If Run Rev = 1 and Run Fwd = 0, the drives rotates in the reverse direction.

Bit 0 - If Run Fwd = 1 and Run Rev = 0, the drives spins in the forward direction.

Note: Net Control must = 1 for Bits 2, 1, 0 to have any affect.

BYTE 1: Must be Zero (00).

BYTE 2: Low Byte of the Speed Ref or Data Value.

BYTE 3: High Byte of the Speed Ref or Data Value.

BYTE 4: Parameter Class, e.g. 0x2A, 0x66, 0x67.

BYTE 5: Parameter Attribute Number, e.g. 0x0A, 0x65.

6.3.4 Class 0x04 - Output instance 100

Instance	Byte	Bit 7	Bit 6	Bit 5	Bit 4	Bit 3	Bit 2	Bit 1	Bit 0
100 0x1A	0	Write Param	Net Ref	Net Ctrl		MRS	Fault Reset	Reverse run	Forward run
	1	00							
	2	Speed setting value (Low Byte)							
	3	Speed setting value (High Byte)							
	4	Acceleration time (Pr. 7) (Low Byte)							
	5	Acceleration time (Pr. 7) (High Byte)							
	6	Deceleration time (Pr. 8) (Low Byte)							
	7	Deceleration time (Pr. 8) (High byte)							

The reading/writing parameter access control, parameter class, parameter attribute number and parameter write data are set with output instance 100 (0x64).

Output instance 100 must be used together in the command requiring parameter access.

Output instance 100 uses 8-byte data.

Output instance 100 is executed with the following rules:

BYTE 0:

Bit7 - If Write Parm is set to 1, the acceleration/deceleration time value will be written into the parameter.
(The write conditions follow Pr. 77.)

Bit7 - If Write Parm is set to 0, the acceleration/deceleration time value will not be written into the parameter.

Bit6 - If NetRef is set to 1, the speed setting value will be incorporated from BYTE2 and BYTE3.

Bit6 - If NetRef is set to 0, the speed setting value will be the value set from the parameter unit.

Bit5 - If NetCtrl is set to 1, MRS, FaultReset, reverse run and forward run can be operated with communication.

Bit5 - If NetCtrl is set to 0, MRS, FaultReset, reverse run and forward run can be operated with the inverter unit's external terminals.

Bit4 - Not used

Bit3 - If MRS is set to 1, the inverter output will be shut off.

Bit3 - If MRS is set to 0, the inverter will cancel the shut off output.

(MRS can be assigned with Pr. 183.)

Bit2 - If FaultReset is changed from 0 to 1, and there is an error in the inverter, the inverter will reset.

Bit1 - If Reverse run is set to 1 and forward run to 0, the motor will reverse run.

Bit0 - If Forward run is set to 1 and reverse run to 0, the motor will forward run.

Note: NetCtrl must be set to 1 to validate Bit3, 2, 1 and 0.

BYTE 1: Must be 00.

BYTE 2: Low-order byte of speed setting value (speed).

BYTE 3: High-order byte of speed setting value (speed).

BYTE 4: Low-order byte of acceleration time.

BYTE 5: High-order byte of acceleration time.

BYTE 6: Low-order byte of deceleration time.

BYTE 7: High-order byte of deceleration time.

6.3.5 Class 0x04 - Input Instance 70

Instance	Byte	Bit 7	Bit 6	Bit 5	Bit 4	Bit 3	Bit 2	Bit 1	Bit 0
70 0x46	0						Run(1) Fwd		Faulted
	1								
	2	Speed Actual (Low Byte)							
	3	Speed Actual (High Byte)							

6.3.6 Class 0x04 - Input Instance 71 (Default)

Instance	Byte	Bit 7	Bit 6	Bit 5	Bit 4	Bit 3	Bit 2	Bit 1	Bit 0
71 0x47	0	At Ref Speed	Ref From Net	Ctrl From Net	Ready	Run(2) Rev	Run(1) Fwd		Faulted
	1								
	2	Speed Actual (Low Byte)							
	3	Speed Actual (High Byte)							

6.3.7 Class 0x04 - Input Instance 76

Instance	Byte	Bit 7	Bit 6	Bit 5	Bit 4	Bit 3	Bit 2	Bit 1	Bit 0
76 0x4C	0	At Ref Speed	Ref From Net	Ctrl From Net	Ready	Run(2) Rev	Run(1) Fwd		Faulted
	1	00							
	2	Speed Actual (Low Byte)							
	3	Speed Actual (High Byte)							
	4	Parameter Read or Monitoring Data (Low Byte)							
	5	Parameter Read or Monitoring Data (High Byte)							

The Input Instance 76 (0x4C) provide 16 bits of parameter data.

Input Instance 76 must be used together with Output Instance 26 in those applications requiring parameter access.

Input Instance 76 utilizes 6 data bytes.

The Input Instance 76 bytes operates in the following manner:

BYTE 0:

Bit 7 - At Ref Speed - The drive is very close to or at the Ref Speed.

Bit 6 - Ref From Net - Speed setting comes from the DeviceNet master.

Bit 5 - Control From Net - Fault Reset, Run Rev, Run Fwd come from the DeviceNet Master.

Bit 4 - Ready.

Bit 3 - Run Rev - Drive is rotating in the reverse direction.

Bit 2 - Run Fwd - Drive is rotating in the forward direction.

Bit 1 - Not Supported.

Bit 0 - The drive is in a fault state.

BYTE 1: Must be zero (00).

BYTE 2: Low Byte of the Speed Actual.

BYTE 3: High Byte of the Speed Actual.

BYTE 4: Low Byte of Parameter or Monitoring Data.

BYTE 5: High Byte of Parameter or Monitoring Data.

6.3.8 Class 0x04 - Input instance 150

Instance	Byte	Bit 7	Bit 6	Bit 5	Bit 4	Bit 3	Bit 2	Bit 1	Bit 0
150 0x96	0			OL	FU		Faulted	Reverse run	Forward run
	1	00							
	2	Actual speed (Low Byte)							
	3	Actual speed (High Byte)							
	4	Output current (Low Byte)							
	5	Output current (High Byte)							
	6	Error cause							
	7	00							

16-bit data is executed with the input instance 150 (0x96).

Input instance 150 must be used together in the command requiring parameter access.

Input instance 150 uses 8-byte data.

Input instance 150 is executed with the following rules:

BYTE 0:

Bit 7 - Not used

Bit 6 - Not used

Bit 5 - If OL is set to 1, the stall prevention is activated.

Bit 5 - If OL is set to 0, the stall prevention is not activated.

Bit 4 - If FU is set to 1, the output frequency is above the set value.

Bit 4 - If FU is set to 0, the output frequency is less the set value.

Bit 3 - Not used

Bit 2 - Faulted - An error has occurred with the inverter.

Bit 1 - Reverse run

Bit 0 - Forward run

BYTE 1: 00

BYTE 2: Low-order byte of actual speed (speed).

BYTE 3: High-order byte of actual speed (speed).

BYTE 4: Low-order byte of output current.

BYTE 5: High-order byte of output current.

BYTE 6: Error cause code when inverter alarm occurs. (Refer to alarm code table provided later.)

BYTE 7: 00

6.4 Class 0x05 - DeviceNet Connection Object

FR-E5ND supports only Polled I/O and Explicit Msgg, not Bit-Strobed I/O.

6.4.1 Class 0x05 Attributes - Instance 0

None. Not Applicable, not related to E500

6.4.2 Class 0x05 Services - Instance 0

None. Not Applicable, not related to E500

6.4.3 Class 0x05 Instance Attributes Instance 1-Explicit Messaging

#	Access	Attribute	Value
1	Get	State	0 to 5
2	Get	Instance Type	0 to 1
3	Get	Transport Trigger Class	0x83
4	Get	Produced Connection ID	0 to 0x07F0
5	Get	Consumed Connection ID	0 to 0x07F0
6	Get	Initial Comm Characteristics	0x33
7	Get	Produced Connection Size	7
8	Get	Consumed Connection Size	7
9	Get/Set	Expected Pack Rate	2504 (Default)
12	Get/Set	Watchdog Action	0 to 2
13	Get	Produced Connection Path Length	0
14	Get/Set	Produced Connection Path	Variable
15	Get	Consumed Connection Path Length	0
16	Get/Set	Consumed Connection Path	Variable

Refer to Vol.I: 5-4 of DeviceNet Specifications for details.

6.4.4 Class 0x05 Instance Attributes Instance 2 - Polled I/O

#	Access	Attribute	Value
1	Get	State	0 to 5
2	Get	Instance Type	0 to 1
3	Get	Transport Trigger Class	0x83
4	Get	Produced Connection ID	0 to 0x07F0
5	Get	Consumed Connection ID	0 to 0x07F0
6	Get	Initial Comm Characteristics	0x01
7	Get	Produced Connection Size	4
8	Get	Consumed Connection Size	4
9	Get/Set	Expected Pack Rate	0 (Default)
12	Get/Set	Watchdog Action	0 to 3
13	Get	Produced Connection Path Length	3
14	Get	Produced Connection Path	0x62 0x34 0x37
15	Get	Consumed Connection Path Length	3
16	Get	Consumed Connection Path	0x62 0x31 0x35

Refer to Vol.1: 5-4 of DeviceNet Specifications for details.

6.4.5 Class 0x05 Instance Attributes Instance 3 - Explicit Messaging

#	Access	Attribute	Value
1	Get	State	0 to 5
2	Get	Instance Type	0 to 1
3	Get	Transport Trigger Class	0x83
4	Get	Produced Connection ID	0 to 0x07F0
5	Get	Consumed Connection ID	0 to 0x07F0
6	Get	Initial Comm Characteristics	0x33
7	Get	Produced Connection Size	7
8	Get	Consumed Connection Size	7
9	Get	Expected Pack Rate	2504 (Default)
12	Get	Watchdog Action	0 to 2
13	Get	Produced Connection Path Length	0
14	Get/Set	Produced Connection Path	Variable
15	Get	Consumed Connection Path Length	0
16	Get/Set	Consumed Connection Path	Variable

6.4.6 Class 0x05 Instance Attributes Instance 4-Explicit Messaging

#	Access	Attribute	Value
1	Get	State	0 to 5
2	Get	Instance Type	0 to 1
3	Get	Transport Trigger Class	0x83
4	Get	Produced Connection ID	0 to 0x07F0
5	Get	Consumed Connection ID	0 to 0x07F0
6	Get	Initial Comm Characteristics	0x33
7	Get	Produced Connection Size	7
8	Get	Consumed Connection Size	7
9	Get/Set	Expected Pack Rate	2504 (Default)
12	Get/Set	Watchdog Action	0 to 2
13	Get	Produced Connection Path Length	0
14	Get	Produced Connection Path	Variable
15	Get	Consumed Connection Path Length	0
16	Get	Consumed Connection Path	Variable

Refer to Vol.I: 5-4 of DeviceNet Specifications for details.

6.4.7 Class 0x05 Instance Attributes Instance 5-Explicit Messaging

#	Access	Attribute	Value
1	Get	State	0 to 5
2	Get	Instance Type	0 to 1
3	Get	Transport Trigger Class	0x83
4	Get	Produced Connection ID	0 to 0x07F0
5	Get	Consumed Connection ID	0 to 0x07F0
6	Get	Initial Comm Characteristics	0x33
7	Get	Produced Connection Size	7
8	Get	Consumed Connection Size	7
9	Get	Expected Pack Rate	2504 (Default)
12	Get/Set	Watchdog Action	0 to 2
13	Get	Produced Connection Path Length	0
14	Get/Set	Produced Connection Path	Variable
15	Get	Consumed Connection Path Length	0
16	Get/Set	Consumed Connection Path	Variable

Refer to Vol.I: 5-4 of DeviceNet Specifications for details.

6.4.8 Class 0x05 Instance Attributes Instance 6-Explicit Messaging

#	Access	Attribute	Value
1	Get	State	0 to 5
2	Get	Instance Type	0 to 1
3	Get	Transport Trigger Class	0x83
4	Get	Produced Connection ID	0 to 0x07F0
5	Get	Consumed Connection ID	0 to 0x07F0
6	Get	Initial Comm Characteristics	0x33
7	Get	Produced Connection Size	7
8	Get	Consumed Connection Size	7
9	Get	Expected Pack Rate	2504 (Default)
12	Get/Set	Watchdog Action	0 to 2
13	Get	Produced Connection Path Length	0
14	Get/Set	Produced Connection Path	Variable
15	Get	Consumed Connection Path Length	0
16	Get/Set	Consumed Connection Path	Variable

Refer to Vol.I: 5-4 of DeviceNet Specifications for details.

6.4.9 Class 0x05 Instance Services - Instances 1, 2, 3, 4, 5, 6

#	Service
0x0E	Get Attribute Single
0x10	Set Attribute Single

6.5 Class 0x28 - Motor Data Object

6.5.1 Class 0x28 Attributes - Instance 0

None. Not Applicable, not related to E500.

6.5.2 Class 0x28 Services - Instance 0

None. Not Applicable, not related to E500.

6.5.3 Class 0x28 Instance Attributes Instance 1

#	Access	Attribute	Value
3	Get/Set	Motor Type	7
6	Get/Set	Electronic Thermal O/L relay (Rated Current) (Pr. 9)	
7	Get/Set	Rated Motor Voltage (Pr. 83)	
8	Get/Set	Motor Capacity (Pr. 80)	
9	Get/Set	Rated Motor Frequency (Pr. 84)	
15	Get/Set	Base Frequency (Pr. 3)	

Refer to Vol.II: 6-29 of DeviceNet Specifications for details.

6.5.4 Class 0x28 Instance Services

#	Service
0x0E	Get Attribute Single
0x10	Set Attribute Single

6.6 Class 0x29 - Control Supervisor Object

6.6.1 Class 0x29 Attributes - Instance 0

None. Not Applicable, not related to E500.

6.6.2 Class 0x29 Services

None. Not Applicable, not related to E500.

6.6.3 Class 0x29 Instance Attributes Instance 1

#	Access	Attribute	Value
3	Get/Set	Run 1	0 to 1
4	Get/Set	Run 2	0 to 1
5	Get/Set	Net Ctrl (Pr. 338)	0 to 1
6	Get	State	0 to 7
7	Get	Running 1	0 to 1
8	Get	Running 2	0 to 1
9	Get	Ready	0 to 1
10	Get	Faulted	0 to 1
12	Get/Set	Fault Rst	0 to 1
15	Get	Ctrl From Net*	0 to 1
16	Get/Set	DNF ault Mode	0 to 1
40	Get/Set	Input Assembly	70 to 150
41	Get/Set	Output Assembly	20 to 100

Note*: This data is only updated after INVRreset or power cycle.
Refer to Vol.II: 6-29 of DeviceNet Specifications for details.

6.6.4 Class 0x29 Instance Services

#	Service
0x0E	Get Attribute Single
0x10	Set Attribute Single

6.7 Class 0x2A - AC Drive Object

6.7.1 Class 0x2A Attributes - Instance 0

None. Not Applicable, not related to E500.

6.7.2 Class 0x2A Services

None. Not Applicable, not related to E500.

6.7.3. Class 0x2A Instance Attributes Instance 1

AC Profile Compatibles

#	Access	Attribute	Value
1	Get	Number of Attributes Supported	1
3	Get	At Reference	0 to 1
4	Get/Set	Net Reference (Pr. 339)	0 to 1
6	Get/Set	Operation (Drive) Mode	0
7	Get/Set	Speed Actual	0 to 0xFFFF
8	Get/Set	Speed Ref	0 to 0xFFFF
9	Get	Current Actual	0 to 0xFFFF
17	Get	Output Voltage	0 to 0xFFFF

#	Access	Attribute	Value
18	Get/Set	Acceleration Time (Pr. 7)	0 to 3600
19	Get/Set	Deceleration Time (Pr. 8)	0 to 3600
20	Get/Set	Minimum Frequency (Pr. 2)	0 to 0xFFFF
21	Get/Set	Maximum Frequency (Pr. 1)	0 to 0xFFFF
29	Get	Ref From Net*	0 to 1

This data is updated only after INVReset or power cycle.

The following variables and parameters are vendor-specific, please refer to Mitsubishi FR-E520S-EC/FR-E540 inverter manuals for more details:

E500 System Environment Variables

#	Access	Attribute	Value
101	Set	INV Reset #	1
102	Set	Pr Clr	0x965A
103	Set	Pr All Clr	0x99AA
105	Set	Pr Clr (Ex Com Pr)	0x5A96
106	Set	Pr All Clr (Ex Com Pr)	0xAA99
112	Get/Set	Running f (RAM)*	30.00Hz
113	Set	Running f (EEPROM)*	30.00Hz
114	Get/Set	INV Status/Ctrl Inp Cmd	0 to 0xFFFF
120	Get/Set	Op Mode/INV Config	

Note*: Write to #112 and #113 can be read out from #112.

#: Please refer to Section 6.10, Item 4 for details.

E500 Real Time Parameters

#	Access	Attribute	Value
141	Get/Set	Alarm History 1/Alarm History All Clr	0 to 0xFFFF
142	Get	Alarm History 2	0 to 0xFFFF
143	Get	Alarm History 3	0 to 0xFFFF
144	Get	Alarm History 4	0 to 0xFFFF
145	Get	Alarm History 5	0 to 0xFFFF
146	Get	Alarm History 6	0 to 0xFFFF
147	Get	Alarm History 7	0 to 0xFFFF
148	Get	Alarm History 8	0 to 0xFFFF
170	Get	Output f (0.01Hz)	0 to 0xFFFF
171	Get	Output I (0.01A)	0 to 0xFFFF
172	Get	Output V (0.1V)	0 to 0xFFFF

Note*: See Section 4.5.2 for bit-maps for I/O terminal monitors.

Table Of Alarm # vs Alarm Code

#	Code	#	Code	#	Code	#	Code	#	Code
10	OC1	41	FAN	B1	PUE	F3	E3	FC	E12
11	OC2	51	UVT	B2	RET	F4	E4	FD	E13
12	OC3	60	OLT	C0	CPU	F5	E5	FE	E14
20	OV1	70	BE	C1	CTE	F6	E6	FF	E15
21	OV2	80	GF	C2	P24	F7	E7		
22	OV3	81	LF	D0	OS	F8	E8		
30	THT	90	OHT	F0	E0	F9	E9		

#	Code	#	Code	#	Code	#	Code	#	Code
31	THM	A0	OPT	F1	E1	FA	E10		
40	FIN	B0	PE	F2	E2	FB	E11		

Please refer to FR-E520S-EC/FR-E540 Instruction Manuals for an explanation of the Alarm Codes.

6.7.4 Class 0x2A Instance Services

#	Service
0x0E	Get Attribute Single
0x10	Set Attribute Single

6.8 Class 0x66 - E500 Extended Object 1

6.8.1 Class 0x66 Attributes - Instance 0

None. Not Applicable, not related to E500.

6.8.2 Class 0x66 Services

None. Not Applicable, not related to E500.

6.8.3 Class 0x66 Instance Attributes Instance 1

E500 Parameters

(Please refer to the relevant E500 Instruction Manual for parameter details)
(Pr. 0 = #10)

#	Access	Attribute		Default Value
10	Get/Set	Pr. 0	Torque Boost	(Note 2)
11	Get/Set	Pr. 1	Maximum Frequency	120.00 Hz
12	Get/Set	Pr. 2	Minimum Frequency	0.00 Hz
13	Get/Set	Pr. 3	Base Frequency	60.00 Hz
14	Get/Set	Pr. 4	Multi Speed Setting (High Speed)	(Note 2)
15	Get/Set	Pr. 5	Multi Speed Setting (Middle Speed)	30.00 Hz
16	Get/Set	Pr. 6	Multi Speed Setting (Low Speed)	10.00 Hz
17	Get/Set	Pr. 7	Acceleration Time	(Note 2)
18	Get/Set	Pr. 8	Deceleration Time	(Note 2)
19	Get/Set	Pr. 9	Electronic Thermal O/L Relay	(Note 2)
20	Get/Set	Pr. 10	DC Injection Brake Operation Frequency	3.00 Hz
21	Get/Set	Pr. 11	DC Injection Brake Operation Time	0.5 s
22	Get/Set	Pr. 12	DC Injection Brake Voltage	6.0 %
23	Get/Set	Pr. 13	Starting Frequency	0.50 Hz
24	Get/Set	Pr. 14	Load Pattern Selection	0
25	Get/Set	Pr. 15	Jog Frequency	5.00 Hz
26	Get/Set	Pr. 16	Jog Acceleration/Deceleration Time	0.5 s
28	Get/Set	Pr. 18	High Speed Maximum Frequency	(Note 2)

OBJECT MAP

#	Access	Attribute		Default Value
29	Get/Set	Pr. 19	Base Frequency Voltage	(Note 3)
30	Get/Set	Pr. 20	Acceleration/Deceleration Reference Frequency	60.00 Hz
31	Get/Set	Pr. 21	Acceleration/Deceleration Time Increments	0
32	Get/Set	Pr. 22	Stall Prevention Operation Level	150.0 %
33	Get/Set	Pr. 23	Stall Prevention Operation Level at Double Speed	(Note 3)
34	Get/Set	Pr. 24	Multi-Speed Setting (Speed 4)	(Note 3)
35	Get/Set	Pr. 25	Multi-Speed Setting (Speed 5)	(Note 3)
36	Get/Set	Pr. 26	Multi-Speed Setting (Speed 6)	(Note 3)
37	Get/Set	Pr. 27	Multi-Speed Setting (Speed 7)	(Note 3)
39	Get/Set	Pr. 29	Acceleration/Deceleration Pattern	0
40	Get/Set	Pr. 30	Regenerative Function Selection	0
41	Get/Set	Pr. 31	Frequency Jump 1A	(Note 3)
42	Get/Set	Pr. 32	Frequency Jump 1B	(Note 3)
43	Get/Set	Pr. 33	Frequency Jump 2A	(Note 3)
44	Get/Set	Pr. 34	Frequency Jump 2B	(Note 3)
45	Get/Set	Pr. 35	Frequency Jump 3A	(Note 3)
46	Get/Set	Pr. 36	Frequency Jump 3B	(Note 3)
47	Get/Set	Pr. 37	Speed Display	0
48	Get/Set	Pr. 38	Frequency at 5V (10V) input	(Note 2)
49	Get/Set	Pr. 39	Frequency at 20 mA input	(Note 2)
51	Get/Set	Pr. 41	Up-to-Frequency Sensitivity	10.0
52	Get/Set	Pr. 42	Output Frequency Detection	6.00 Hz
53	Get/Set	Pr. 43	Output Frequency Detection for Reverse Rotation	(Note 3)
54	Get/Set	Pr. 44	Second Acceleration/Deceleration Time	(Note 2)

OBJECT MAP

#	Access	Attribute		Default Value
55	Get/Set	Pr. 45	Second Deceleration Time	(Note 3)
56	Get/Set	Pr. 46	Second Torque Boost	(Note 3)
57	Get/Set	Pr. 47	Second V/F (base frequency)	(Note 3)
58	Get/Set	Pr. 48	Second Electronic Overcurrent Protection	150.0 %
62	Get/Set	Pr. 52	PU Main Display Data Selection	0
64	Get/Set	Pr. 54	FM Terminal Function Selection	1 (Note 2)
65	Get/Set	Pr. 55	Frequency Monitoring Reference	60.00 Hz
66	Get/Set	Pr. 56	Current Monitoring Reference	(Note 2)
67	Get/Set	Pr. 57	Restart Coasting Time	(Note 3)
68	Get/Set	Pr. 58	Restart Cushion Time	1.0 s
69	Get/Set	Pr. 59	Remote Setting Function Selection	0
70	Get/Set	Pr. 60	Shortest Acceleration/deceleration Mode	0
71	Get/Set	Pr. 61	Reference Current	(Note 3)
72	Get/Set	Pr. 62	Reference Current for Intelligent Mode Acceleration.	(Note 3)
73	Get/Set	Pr. 63	Reference Current for Intelligent Mode Deceleration.	(Note 3)
75	Get/Set	Pr. 65	Retry Selection	0
76	Get/Set	Pr. 66	Start Prevention Operation Level Reduction Starting Frequency	60.00 Hz
77	Get/Set	Pr. 67	Number of Retries at Alarm Occurance	0
78	Get/Set	Pr. 68	Retry Waiting Time	1.0 s
79	Get/Set	Pr. 69	Retry Count Display Erase	0
80	Get/Set	Pr. 70	Special Regenerative Brake Duty	0.0 %
81	Get/Set	Pr. 71	Applied Motor	0
82	Get/Set	Pr. 72	PWM Frequency Selection	1 kHz
83	Get/Set	Pr. 73	0 to 5 V/0 to 10 V Select	1

OBJECT MAP

#	Access	Attribute		Default Value
84	Get/Set	Pr. 74	Filter Time Constant	1
85	Get/Set	Pr. 75	Reset Selection/disconnected PU detection/PU stop selection	0
87	Get	Pr. 77	Parameter Write Disable Selection	0
88	Get/Set	Pr. 78	Reverse Rotation Prevention Selection	0
89	Get	Pr. 79	Operation Mode Selection	0
90	Get/Set	Pr. 80	Motor Capacity	(Note 3)
92	Get/Set	Pr. 82	Motor Exciting Current	(Note 3)
93	Get/Set	Pr. 83	Rated Motor Voltage	(Note 2)
94	Get/Set	Pr. 84	Rated Motor Frequency	60.00 Hz
100	Get/Set	Pr. 90	Motor constant (R1)	(Note 3)
106	Get/Set	Pr. 96	Auto Tuning Setting/Status	0
127	Get/Set	Pr. 117	Station Number	0
128	Get/Set	Pr. 118	Communication Speed	192
129	Get/Set	Pr. 119	Stop Bit Length/data length	1
130	Get/Set	Pr. 120	Parity Check Presence/Absence	2
131	Get/Set	Pr. 121	Number Of Communication Retries	1
132	Get/Set	Pr. 122	Communication Check Time Interval	0.0 s
133	Get/Set	Pr. 123	Waiting Time Setting	(Note 3)
134	Get/Set	Pr. 124	CR, LF Presence/Absence Selection	1
138	Get/Set	Pr. 128	PID Action Selection	10
139	Get/Set	Pr. 129	PID Proportionnal Band	100.0 %
140	Get/Set	Pr. 130	PID Integral Time	1.0 s
141	Get/Set	Pr. 131	PID Upper Limit	(Note 3)
142	Get/Set	Pr. 132	PID Lower Limit	(Note 3)

OBJECT MAP

#	Access	Attribute		Default Value
143	Get/Set	Pr. 133	PID Action Set Point For PU Operation	0.00 %
144	Get/Set	Pr. 134	PID Differential Time	(Note 3)
155	Get/Set	Pr. 145	PU Display Language (FR-PU04)	(Note 2)
156	Get/Set	Pr. 146	Parameter Set by Manufacturer. Do not set.	—
160	Get/Set	Pr. 150	Output Current Detection Level	150.0 %
161	Get/Set	Pr. 151	Output Current Detection Period	0.0 s
162	Get/Set	Pr. 152	Zero-Current Detection Level	5.0 %
163	Get/Set	Pr. 153	Zero-Current Detection Period	0.50 s
166	Get/Set	Pr. 156	Stall Prevention Operation Selection	0
168	Get/Set	Pr. 158	AM Terminal Function Selection	1 (Note 2)
170	Get/Set	Pr. 160	User group read selection	0
178	Get	Pr. 168	Parameter set by manufacturer, do not set.	—
179	Get	Pr. 169	Parameter set by manufacturer, do not set.	—
181	Get/Set	Pr. 171	Actual Operation Hour Meter Clear	0
183	Get/Set	Pr. 173	User Group 1 Registration	0
184	Get/Set	Pr. 174	User Group 1 Deletion	0
185	Get/Set	Pr. 175	User Group 2 Registration	0
186	Get/Set	Pr. 176	User Group 2 Deletion	0
190	Get/Set	Pr. 180	(RL) Function Selection	0
191	Get/Set	Pr. 181	(RM) Function Selection	1
192	Get/Set	Pr. 182	(RH) Function Selection	2
193	Get/Set	Pr. 183	MRS Terminal (MRS) Function Selection	3

#	Access	Attribute	Default Value
200	Get/Set	Pr. 190 (RUN) Function Selection	0
201	Get/Set	Pr. 191 (FU) Function Selection	1
202	Get/Set	Pr. 192 A, B, C Terminal (ABC) Function Selection	2
212	Get/Set	Pr. 232 Multi-Speed Setting (Speed 8)	(Note 3)
213	Get/Set	Pr. 233 Multi-Speed Setting (Speed 9)	(Note 3)
214	Get/Set	Pr. 234 Multi-Speed Setting (Speed 10)	(Note 3)
215	Get/Set	Pr. 235 Multi-Speed Setting (Speed 11)	(Note 3)
216	Get/Set	Pr. 236 Multi-Speed Setting (Speed 12)	(Note 3)
217	Get/Set	Pr. 237 Multi-Speed Setting (Speed 13)	(Note 3)
218	Get/Set	Pr. 238 Multi-Speed Setting (Speed 14)	(Note 3)
219	Get/Set	Pr. 239 Multi-Speed Setting (Speed 15)	(Note 3)
220	Get/Set	Pr. 240 Soft-PWM Setting	
224	Get/Set	Pr. 244 Cooling fan operation selection	0
225	Get/Set	Pr. 245 Rated motor slip	9999
226	Get/Set	Pr. 246 Slip compensation response time	0.5 s
227	Get/Set	Pr. 247 Constant output region slip compensation selection	9999
229	Get/Set	Pr. 249 Ground fault detection at start	0 (Note 2)
230	Get/Set	Pr. 250 Stop selection	9999

Note 1: Parameters marked "Special" should not be changed under normal operating conditions. Improper inverter operation and damage to equipment may occur.

Note 2: Some default values depend on the capacity, voltage class or type (EC, NA etc.) of the inverter.

Note 3: The default values 65535, 6553.5 Unit, 655.35 Unit simply indicate the function is NOT Active. These settings will be reflected as "9999" when viewed via the inverter parameter unit.

Note *: Changing the value will generate the actual effects, but is NOT reflected correctly in DeviceNet Manager.

6.8.4 Class 0x66 Instance Services

#	Service
0x0E	Get Attribute Single
0x10	Set Attribute Single

6.9 Class 0x67 - E500 Extended Object II

6.9.1 Class 0x67 Attributes - Instance 0

None. Not Applicable, not related to E500.

6.9.2 Class 0x67 Services

None. Not Applicable, not related to E500.

6.9.3 Class 0x67 Instance Attributes Instance 1

More E500 Parameters

(Please refer to the relevant E500 Instruction Manual for Details)

#	E500 Pr.	Access	Attribute	Default Value
38	Pr. 338	Get/Set	Operation control mode source	0
39	Pr. 339	Get/Set	Speed command source	0
40	Pr. 340	Get/Set	Link start-up mode selection	0
42	Pr. 342	Get/Set	Setting of the EEPROM by the FR-E5ND	0
45	Pr. 345	Get/Set	DeviceNet mode address data (Lower byte)	63
46	Pr. 346	Get/Set	DeviceNet baud rate data (Lower byte)	132

#	E500 Pr.	Access	Attribute	Default Value
47	Pr. 347	Get/Set	DeviceNet mode address data (Higher byte)	160
48	Pr. 348	Get/Set	DeviceNet baud rate data (higher byte)	80

Calibration Functions

#	E500 Pr.	Access	Attribute	Default Value
202	Pr. 902 Freq	Get/Set	Frequency Voltage Bias - Frequency	0.00 Hz
203	Pr. 902 %	Get/Set	Frequency Voltage Bias - Percent	0.0 %
204	Pr. 903 Freq	Get/Set	Frequency Voltage Gain - Frequency	60.00 Hz
205	Pr. 903 %	Get/Set	Frequency Voltage Gain - Percent	97.0 %
206	Pr. 904 Freq	Get/Set	Frequency Current Bias - Frequency	0.00 Hz
207	Pr. 904 %	Get/Set	Frequency Current Bias - Percent	18.8 %
208	Pr. 905 Freq	Get/Set	Frequency Current Gain - Frequency	60.00 Hz
209	Pr. 905 %	Get/Set	Frequency Current Gain - Percent	92.7 %

Note 1: Parameters marked "Special" should not be changed under normal operating conditions. Improper inverter operation and damage to equipment may occur.

Note 2: Some default values depend on the capacity, voltage and type (i.e. EC, NA) of inverter.

Note 3: The default values 65535, 6553.5 Unit, 655.35 Unit simply indicate the function is NOT Active. These settings will be reflected as "9999" when viewed via the inverter parameter unit.

6.9.4 Class 0x67 Instance Services

#	Service
0x0E	Get Attribute Single
0x10	Set Attribute Single

6.10 Response Timing

- Item 1. Polling - Reading & Request Without Changing State:
Explicit Messaging (G2 and G3) - Get-Attribute-Reading Data:

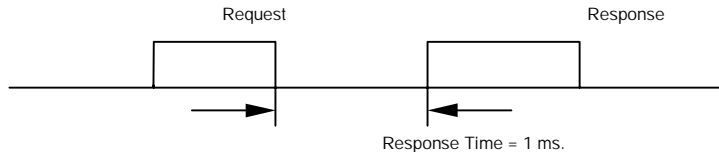

- Item 2. Polling - Writing & Request With Changing State:
Explicit Messaging (G2 and G3) - Set-Attribute-Writing Data (Excluding Items 3 and 4):

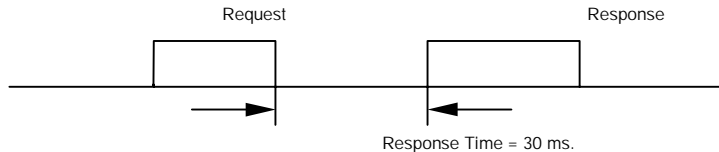

Item 3. PrClr, PrAllClr, PrClr (ECP), PrAllClr (ECP):

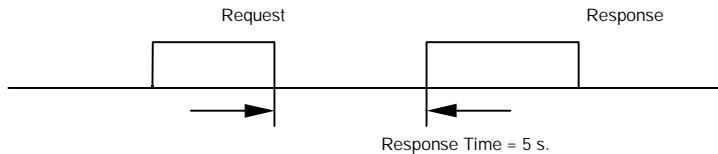

Item 4. Inverter reset and Pr. 340 = 0:
The drive will go to Ext-mode afterwards.

6.11 Recommendation For Software Developers

For software developers only:

- a. Make a handshake procedure, send a request, wait for response, then go to next request.
- b. Set waiting time between each message based on FR-E5ND specifications above, e.g. for reading set to 1 ms each time; for writing set to 30 ms each time.

7. E500 PARAMETERS

E500 PARAMETERS

Pr. No.	Function	E5ND	EDS	COM-MON	Object	Attribute/service	Attr id/svc code	Attr/svc name
0	Torque Boost	•	•		E500_66	Attrib	10	
1	Maximum Frequency	•	•	•	AC Drive	Attrib	21	HiSpd Limit
		•	•		E500_66	Attrib	11	
2	Minimum Frequency	•	•	•	AC Drive	Attrib	20	LoSpd Limit
		•	•		E500_66	Attrib	12	
3	Base Frequency	•	•	•	Motr Data/ AC MotrInst	Attrib	9	Rated f
		•	•		E500_66	Attrib	13	
4	Multi-Speed Setting (High Speed)	•	•		E500_66	Attrib	14	
5	Multi-Speed Setting (Middle Speed)	•	•		E500_66	Attrib	15	
6	Multi-Speed Setting (Low Speed)	•	•		E500_66	Attrib	16	
7	Acceleration Time	•	•	•	AC Drive	Attrib	18	Acc t
		•	•		E500_66	Attrib	17	
8	Deceleration Time	•	•	•	AC Drive	Attrib	19	Dec t
		•	•		E500_66	Attrib	18	
9	Electrical Thermal O/L Relay	•	•		E500_66	Attrib	19	
10	DC Injection Brake Operation Frequency	•	•		E500_66	Attrib	20	
11	DC Injection Brake Operation Time	•	•		E500_66	Attrib	21	
12	DC Injection Brake Voltage	•	•		E500_66	Attrib	22	
13	Starting Frequency	•	•		E500_66	Attrib	23	
14	Load Pattern Selection	•	•		E500_66	Attrib	24	

E500 PARAMETERS

Pr. No.	Function	E5ND	EDS	COM-MON	Object	Attribute/service	Attr id/ svc code	Attr/svc name
15	Jog Frequency	•	•		E500_66	Attrib	25	
16	Jog Acceleration/Deceleration Time	•	•		E500_66	Attrib	26	
18	High Speed Maximum Frequency	•	•	•	AC Drive	Attrib	21	Hispd Limit
		•	•		E500_66	Attrib	28	
19	Base Frequency Voltage	•	•	•	Motr Data/ ACM MotrInst	Attrib	7	Rated V
		•	•		E500_66	Attrib	29	
20	Acceleration/Deceleration Reference Frequency	•	•		E500_66	Attrib	30	
21	Acceleration/Deceleration Time Increments	•	•		E500_66	Attrib	31	
22	Stall Prevention Operation Level	•	•		E500_66	Attrib	32	
23	Stall Prevention Operation Level at Double Speed	•	•		E500_66	Attrib	33	
24	Multi-Speed Setting (Speed 4)	•	•		E500_66	Attrib	34	
25	Multi-Speed Setting (Speed 5)	•	•		E500_66	Attrib	35	
26	Multi-Speed Setting (Speed 6)	•	•		E500_66	Attrib	36	
27	Multi-Speed Setting (Speed 7)	•	•		E500_66	Attrib	37	
29	Acceleration/Deceleration Pattern	•	•		E500_66	Attrib	39	
30	Regenerative Function Selection	•	•		E500_66	Attrib	40	
31	Frequency Jump 1A	•	•		E500_66	Attrib	41	
32	Frequency Jump 1B	•	•		E500_66	Attrib	42	

E500 PARAMETERS

Pr. No.	Function	E5ND	EDS	COM-MON	Object	Attribute/service	Attr id/svc code	Attr/svc name
33	Frequency Jump 2A	•	•		E500_66	Attrib	43	
34	Frequency Jump 2B	•	•		E500_66	Attrib	44	
35	Frequency Jump 3A	•	•		E500_66	Attrib	45	
36	Frequency Jump 3B	•	•		E500_66	Attrib	46	
37	Speed Display	•	•		E500_66	Attrib	47	
38	Frequency at 20 mA input	•	•		E500_66	Attrib	48	
39	Frequency at 5 V (10 V) input	•	•		E500_66	Attrib	49	
41	Up to Frequency Sensitivity	•	•		E500_66	Attrib	51	
42	Output Frequency Detection	•	•		E500_66	Attrib	52	
43	Output Frequency Detection for Reverse Rotation	•	•		E500_66	Attrib	54	
44	Second Acceleration/Deceleration Time	•	•		E500_66	Attrib	54	
45	Second Deceleration Time	•	•		E500_66	Attrib	55	
46	Second Torque Boost	•	•		E500_66	Attrib	56	
47	Second V/F (base frequency)	•	•		E500_66	Attrib	57	
48	Second Electronic Overcurrent Protection	•	•		E500_66	Attrib	58	
52	PU Main Display Data Selection	•	•		E500_66	Attrib	62	
54	FM Terminal Function Selection	•	•		E500_66	Attrib	64	
55	Frequency Monitoring Reference	•	•		E500_66	Attrib	65	
56	Current Monitoring Reference	•	•		E500_66	Attrib	66	
57	Restart Coasting Time	•	•		E500_66	Attrib	67	
58	Restart Cushion Time	•	•		E500_66	Attrib	68	
59	Remote Setting Function Selection	•	•		E500_66	Attrib	69	

E500 PARAMETERS

Pr. No.	Function	E5ND	EDS	COM-MON	Object	Attribute/service	Attr id/svc code	Attr/svc name
60	Shortest Acceleration/deceleration Mode	•	•		E500_66	Attrib	70	
61	Reference Current	•			E500_66	Attrib	71	
62	Reference Current for Intelligent Mode Acceleration	•			E500_66	Attrib	72	
63	Reference Current for Intelligent Mode Deceleration	•			E500_66	Attrib	73	
65	Retry Selection	•	•		E500_66	Attrib	75	
66	Stall Prevention Operation Level Reduction Starting Frequency	•	•		E500_66	Attrib	76	
67	Number of Retries at Alarm Occurrence	•	•		E500_66	Attrib	77	
68	Retry Waiting Time	•	•		E500_66	Attrib	78	
69	Retry Count Display Erasure	•	•		E500_66	Attrib	79	
70	Special Regenerative Brake Duty	•	•		E500_66	Attrib	80	
71	Applied Motor	•	•		E500_66	Attrib	81	
72	PWM Frequency Selection	•	•		E500_66	Attrib	82	
73	0 to 5 V/0 to 10 V Selection	•	•		E500_66	Attrib	83	
74	Filter Time Constant	•	•		E500_66	Attrib	84	
75	Reset Selection/disconnected PU detection/PU stop selection	•	•		E500_66	Attrib	85	
77	Parameter Write Disable Selection	•	•		E500_66	Attrib	87	
78	Reverse Rotation Prevention Selection	•	•		E500_66	Attrib	88	
79	Operation Mode Selection	•	•		E500_66	Attrib	89	
80	Motor Capacity	•	•		E500_66	Attrib	90	

E500 PARAMETERS

Pr. No.	Function	E5ND	EDS	COM-MON	Object	Attribute/service	Attr id/ svc code	Attr/svc name
82	Motor Exciting Current	.			E500_66	Attrib	92	
83	Rated Motor Voltage	.	.	.	Motr Data/ AC MotrInst	Attrib	7	Rated V
		.	.		E500_66	Attrib	93	
84	Rated Motor Frequency	.	.	.	Motr Data/ AC MotrInst	Attrib	9	Rated f
		.	.		E500_66	Attrib	94	
90	Motor Constant (R1)	.	.		E500_66	Attrib	100	
96	Auto Tuning Setting/Status	.	.		E500_66	Attrib	106	
117	Station Number	.	.		E500_66	Attrib	127	
118	Communication Speed	.	.		E500_66	Attrib	128	
119	Stop Bit length/data length	.	.		E500_66	Attrib	129	
120	Parity Check Presence/Absence Selection	.	.		E500_66	Attrib	130	
121	Number Of Communication Retries	.	.		E500_66	Attrib	131	
122	Communication Check Time Interval	.	.		E500_66	Attrib	132	
123	Waiting Time Setting	.	.		E500_66	Attrib	133	
124	CR, LF Presence/Absence Selection	.	.		E500_66	Attrib	134	
128	PID Action Selection	.	.		E500_66	Attrib	138	
129	PID proportional Band	.	.		E500_66	Attrib	139	
130	PID Integral Time	.	.		E500_66	Attrib	140	
131	PID Upper Limit	.	.		E500_66	Attrib	141	
132	PID Lower Limit	.	.		E500_66	Attrib	142	
133	PID Action Set Point For PU Operation	.	.		E500_66	Attrib	143	

E500 PARAMETERS

Pr. No.	Function	E5ND	EDS	COM-MON	Object	Attribute/service	Attr id/ svc code	Attr/svc name
134	PID Differential Time	•	•		E500_66	Attrib	144	
145	PU Display Language (FR-PU04)	•	•		E500_66	Attrib	155	
146	Parameter Set by Manufacturer. Do not set.	•	•		E500_66	Attrib	156	
150	Output Current Detection Level	•	•		E500_66	Attrib	160	
151	Output Current Detection Period	•	•		E500_66	Attrib	161	
152	Zero Current Detection Level	•	•		E500_66	Attrib	162	
153	Zero Current Detection Period	•	•		E500_66	Attrib	163	
156	Stall Prevention Operating Selection	•	•		E500_66	Attrib	166	
158	AM Terminal Function Selection	•	•		E500_66	Attrib	168	
160	User group read selection	•	•		E500_66	Attrib	172	
168	Reserved	•	•		E500_66	Attrib	178	
169	Reserved	•	•		E500_66	Attrib	179	
171	Actual Operating Hour Meter Clear	•	•		E500_66	Attrib	181	
173	User Group 1 Registration	•	•		E500_66	Attrib	183	
174	User Group 1 Deletion	•	•		E500_66	Attrib	184	
175	User Group 2 Registration	•	•		E500_66	Attrib	185	
176	User Group 2 Deletion	•	•		E500_66	Attrib	186	
180	RL Terminal Function Selection	•	•		E500_66	Attrib	190	
181	RM Terminal Function Selection	•	•		E500_66	Attrib	191	
182	RH Terminal Function Selection	•	•		E500_66	Attrib	192	
183	MRS Terminal Function Selection	•	•		E500_66	Attrib	193	
190	RUN Terminal Function Selection	•	•		E500_66	Attrib	200	

E500 PARAMETERS

Pr. No.	Function	E5ND	EDS	COM-MON	Object	Attribute/service	Attr id/svc code	Attr/svc name
191	FU Terminal Function Selection	•	•		E500_66	Attrib	201	
192	A, B, C Terminal Function Selection	•	•		E500_66	Attrib	202	
232	Multi-Speed Setting (Speed 8)	•	•		E500_66	Attrib	212	
233	Multi-Speed Setting (Speed 9)	•	•		E500_66	Attrib	213	
234	Multi-Speed Setting (Speed 10)	•	•		E500_66	Attrib	214	
235	Multi-Speed Setting (Speed 11)	•	•		E500_66	Attrib	215	
236	Multi-Speed Setting (Speed 12)	•	•		E500_66	Attrib	216	
237	Multi-Speed Setting (Speed 13)	•	•		E500_66	Attrib	217	
238	Multi-Speed Setting (Speed 14)	•	•		E500_66	Attrib	218	
239	Multi-Speed Setting (Speed 15)	•	•		E500_66	Attrib	219	
240	Soft-PWM Setting	•	•		E500_66	Attrib	220	
244	Cooling fan Operation Selection	•	•		E500_66	Attrib	224	
245	Rated Motor Slip	•	•		E500_66	Attrib	225	
246	Slip Compensation Response Time	•	•		E500_66	Attrib	226	
247	Constant Output Region Slip Compensation Selection	•	•		E500_66	Attrib	227	
250	Stop Selection	•	•		E500_66	Attrib	230	
338	Operation Control Mode Source	•	•		E500_67	Attrib	38	
339	Speed Command Source	•	•		E500_67	Attrib	39	
340	Link Start-up Mode Selection	•	•		E500_67	Attrib	40	
345	DeviceNet Mode Address Data (Lower Byte)	•	•		E500_67	Attrib	45	
346	DeviceNet Baud Rate Data (Lower Byte)	•	•		E500_67	Attrib	46	

E500 PARAMETERS

Pr. No.	Function	E5ND	EDS	COM-MON	Object	Attribute/service	Attr id/svc code	Attr/svc name
347	DeviceNet Mode Address Data (Higher Byte)	•	•		E500_67	Attrib	47	
348	DeviceNet Baud Rate Data (Higher Byte)	•	•		E500_67	Attrib	48	
367	Special	•	•		E500_67	Attrib	67	
368	Special	•	•		E500_67	Attrib	68	
902	Frequency Voltage Bias (Frequency)	•	•		E500_67	Attrib	202	
	Frequency Voltage Bias (%)	•	•		E500_67	Attrib	203	
903	Frequency Voltage Gain (Frequency)	•	•		E500_67	Attrib	204	
	Frequency Voltage Gain (%)	•	•		E500_67	Attrib	205	
904	Frequency Current Bias (Frequency)	•	•		E500_67	Attrib	206	
	Frequency Current Bias (%)	•	•		E500_67	Attrib	207	
905	Frequency Current Gain (Frequency)	•	•		E500_67	Attrib	208	
	Frequency Current Gain (%)	•	•		E500_67	Attrib	209	
990	Buzzer Beep Control (FR-PU04)	•	•		E500_66	Attrib	250	
991	LCD Contrast (FR-PU04)	•	•		E500_67	Attrib	251	
	Inverter Reset	•	•		AC Drive	Attrib	101	
	Parameter Clear	•	•		AC Drive	Attrib	102	
	Parameter All Clear	•	•		AC Drive	Attrib	103	
	Parameter Clear (Ex Com Pr)	•	•		AC Drive	Attrib	105	
	Parameter All Clear (Ex Com Pr)	•	•		AC Drive	Attrib	106	
	Running Frequency (RAM)	•	•		AC Drive	Attrib	112	

E500 PARAMETERS

Pr. No.	Function	E5ND	EDS	COM-MON	Object	Attribute/service	Attr id/ svc code	Attr/svc name
	Running Frequency (EEPROM)	•	•		AC Drive	Attrib	113	
	Inverter Status/Control Input Cmd	•	•		AC Drive	Attrib	114	
	Jog Operating Frequency (Setting)	•	•		AC Drive	Attrib	115	
	Op Mode/Inverter Configuration	•	•		AC Drive	Attrib	120	
	Alarm History 1/Alarm History All Clear	•	•		AC Drive	Attrib	141	

8. TROUBLESHOOTING

TROUBLESHOOTING

If a fault occurs and the inverter fails to operate properly, locate the cause of the fault and take proper corrective action by referring to the troubleshooting below. If the corresponding information is not found in the table, the inverter has a problem, or the component parts are damaged, contact the nearest service representative.

8.1 Inspecting the Display On Parameter Unit and LED2 (MNS) Status LED On the E5ND

In response to the occurrence of a fault, the display unit of the inverter automatically displays the code of the detected fault and LED2 (MNS) Status LED on E5ND shows the status of the detected fault.

Display		Possible Cause	Check	Corrective Action
E520S/E540	LED (MNS) On E5ND			
E.OPT	Blinking Red	Connection time-out, Master designated E5ND for communication, but sent no msgs within time limit = $4 \times \text{EPR}$.	Host station has not been disconnected from network.	Reset the Inverter. Reconnect the network. Master is up and running. Master sends message(s) within time limit.
0.00	Off	No good contact between E500 and E5ND.	E5ND was not plugged in firmly.	Follow the instructions in Section 2, plug in E5ND firmly.
0.00	Red	Duplicate station number, Network power off, Network cable offline; E5ND is only node, not even a Master is present. Network is damaged.	No duplicate station numbers; Network power on; No damage to network; All cables are in proper connection; Master is on network.	Check required items in left box, Reset the Inverter, Reset the network.

Note: It should be noted that the EPR setting refers to the EPR set by the DeviceNet master.

9. SPECIFICATIONS

SPECIFICATIONS

- 1) Power supply
 - Control Power: supplied by the inverter.
 - Communication power: supplied by DeviceNet power supply, 11 to 28 V with a 10 A capacity
- 2) Standard
 - Conforms to ODVA DeviceNet Specification Release 2.0 (independently tested by University of Michigan test lab, April, 1999); supports UCMM
- 3) Network topology
 - DeviceNet (linear bus with drop lines)
- 4) Transmission Media
 - DeviceNet standard thick or thin cable
- 5) Maximum cable distance
 - 500 m at 125 k baud with thick cable (see DeviceNet specification for details on maximum cable distance for different baud rates)
- 6) Transmission speed
 - 125 kbps, 250 kbps, 500 kbps
- 7) Number of inverters connectable
 - 63 inverters with minimum of one node as a master
- 8) Supported inverters
 - FR-E520S-EC/FR-E540
- 9) Environmental

Ambient temperature	-10 to 50°C (non-condensing)
Ambient humidity	90 % or less (non-condensing)
Vibration	5.9 m/s ² or less, conforming to JIS-C0912
Protective structure	Open type (IP00), JEM1030

Appendix 1 Electronic Data Sheet

Electronic Data Sheets (EDS files)

The EDS file for the E500 series inverters is available in the following. Contact your local distributor.

Please consult your DeviceNet configuration software instruction manual for the proper installation of the EDS file.

REVISIONS

*The manual number is given on the bottom left of the back cover.

Print Date	*Manual Number	Revision
Apr. 1999	IB(NA)-0600006-A	First edition
	IB(NA)-0600006-B	Mistakes corrected

TRANSISTORIZED INVERTER



HEAD OFFICE: MITSUBISHI DENKI BLDG MARUNOUCHI TOKYO 100