

**Mitsubishi
Electric
Automation
Instruction Manual**

FR-A5AN

Analog Input-Output Option



NOTES, CAUTIONS AND WARNINGS

NOTE: Notes are used to provide additional detail about a procedure. The Note will always precede the text that the Note refers to.

CAUTION:  Cautions provide additional detail where failure to observe the Caution may result in damage to the equipment or slight injury to the user.

WARNING:  Warnings provide additional information, where failure to observe the Warning may result in death or severe injury

SAFETY INSTRUCTION

1. Electric Shock Prevention

WARNING:  • Do not open or remove the front cover while the Variable Frequency Drive is running. You may get an electrical shock.

- When necessary to perform inspections or when wiring the unit, switch power off and wait at least 10 minutes and until the bus charge light is off. Check for residual voltage.
- Do not attempt to inspect or wire this unit unless you are fully competent to perform the work.
- Be sure hands are dry before operating any switches.
- Be sure cables do not have scratches, excessive stress, heavy loads or pinching to prevent electrical shock

2. Injury Prevention

CAUTION:  • Be sure all connections are in accordance with instructions in this manual

- Check that cables are properly connected before turning equipment on.

- After turning equipment off, wait at least 10 minutes and until the bus charge light is off before removing cover. With cover removed, charged components may be exposed.

3. Additional Cautions and Warnings

CAUTION:



- Do not install the option unit if it is damaged or has parts missing
- Check that option unit is securely fastened to the variable frequency drive.
- Do not stand or rest heavy objects on top of unit.
- Do not allow metal fragments, conductive bodies, oil or other flammable substance to enter the variable frequency drive.
- Before starting operation, confirm and adjust the parameters. Failure to do so may cause the machines to make unexpected motions.
- When parameter clear or all parameter clear is performed, each parameter returns to the factory setting. Reset the required parameters before starting operation
- For prevention of damage caused by static buildup, touch a nearby grounded metal object to remove static from your body.
- Dispose of this product as general industrial waste.

WARNING:



- Do not modify this equipment

Table of Contents

Table of Contents	3
1. Introduction.....	5
1.1. Structure.....	6
<i>Figure 1: Top view</i>	6
<i>Figure 2: Connection Diagram</i>	6
2. Installation	7
2.1 Unpacking the FR-A5AN Option	7
<i>Figure 3: Option Cable</i>	7
2.2 Pre-Installation Checks.....	8
<i>Table 1: A560(L) VFD Compatibility Chart</i>	8
2.3 Mounting Procedure	9
<i>Figure 4: Drive View</i>	10
<i>Figure 5: Cable Routing View</i>	10
<i>Figure 6: Wiring Diagram</i>	11
3. FR-A5AN Operation.....	13
3.1 Analog Input/Output Terminals.....	13
<i>Table 2: FR-A5AN I/O Terminal Description</i>	13
3.1.1 Operating Functions	14
<i>Table 3: Input/Output Signal Parameters</i>	15
<i>Table 4: Control Signal Parameter Settings</i>	18
3.2 Analog Output Selection Signal.....	18
<i>Table 5: Output Selection Signal Settings</i>	19
3.3 Analog Output Setting for Zero Input and Maximum Input.....	20
<i>Figure 7: Output Graph</i>	20
3.4 Analog Output Signal Switching for Channel 1 & 2	20
<i>Table 6: Signal Switching Channel 1 & 2 Settings</i>	21
3.5 FR-A5AN analog Output Calibration ..	21
3.6 FR-A5AN analog Input Calibration.....	23

4. FR-A5AN Specifications	24
5. References	25
Mitsubishi Electric.....	25
Technical Support Number.....	25
6. Revisions	25
7. User Note's Section.....	26

1. Introduction

Thank you for choosing this option unit for the Mitsubishi FR-A560(L) series transistorized frequency VFD's.

Please read this manual carefully before using this option unit. This instruction manual gives handling information and precautions for use of this product as well as the information required for the installation of the FR-A5AN option.

It is assumed that the reader of this manual possesses an understanding of the configuration, implementation, and operation of Mitsubishi FR-A560(L) series drives

Please forward this manual to the end user.

Analog Input-Output Option (FR-A5AN)

This option unit lets you control a FR-A560(L) series VFD with an analog input signal which is isolated and connected to the FR-A560(L) signal input terminal block. This option also permits the user to output two analog signals from one of several drive functions.

Some important features of this option unit include:

- All input / output signals are electrically isolated to 1000 volts independently and from the VFD.
- User selectable input / output functions.
- Can be used with communications options.
- Designed and assembled in the U.S.A.

1.1. Structure

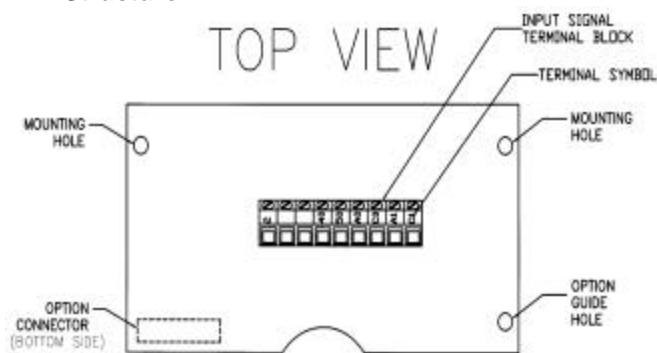

Figure 1: Top view

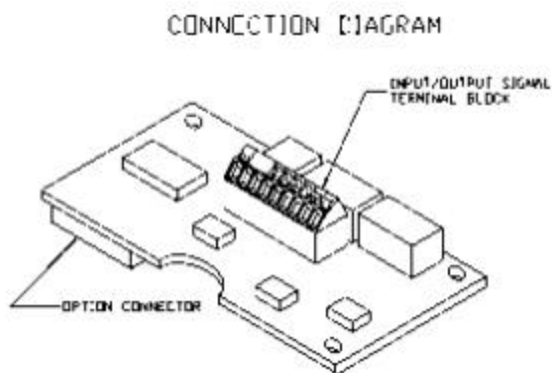

Figure 2: Connection Diagram

2. Installation

2.1 Unpacking the FR-A5AN Option

1. Check that all required components were received from the factory. The FR-A5AN option should have the following items included.
 - ◆ 1 Instruction Manual
VC2BNA00028
 - ◆ 1 Option Terminal Block Cable
VC2C105A017

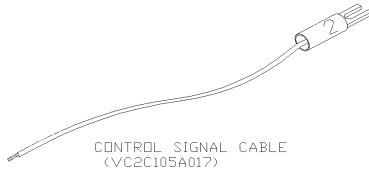

Figure 3: Option Cable

- ◆ 1 FR-A5AN Option packed in an anti-static bag.
C2C132U075
 - ◆ 2 3 x 8 mm Machine Screws
VSP896M205
2. The FR-A5AN option should be left in the anti-static bag until installation to prevent damage caused by ESD.



The option module is sensitive to electro-static discharge. Proper ESD measures required.

2.2 Pre-Installation Checks

Remove the drive cover carefully, following the VFD instruction manual. Be sure to install the option unit using the following procedure:

1. Check the VFD type: The FR-A5AN option will only be recognized and be fully functional with the following A560(L) series variable frequency drives manufactured after the following dates. For all drives manufactured prior to this date the FR-A5AN will not function. This option was developed after the introduction of the A560(L) series drives, therefore firmware support for this option is only available with drives manufactured with the following serial numbers or production dates. The manufacturing date and version can be identified and verified by the serial number located on the VFD. The serial number is made up of 9 characters, a version letter and 8 numerals. The first two numerals represent the year it was manufactured followed by a 6 digit Mitsubishi control number.

Model	Date Introduced	Serial Number
FR-A560-0.4K~22K-NA	Planned July 2000	N/A

Table 1: A560(L) VFD Compatibility Chart

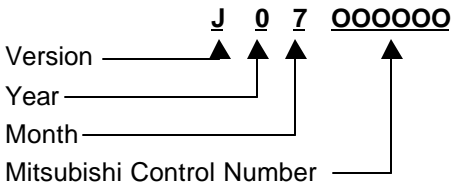

You must not use it with any other series (e.g. A200E, A200, A100, Z and F series). These other series VFD's have a different option connector to prevent installation; if you force the connector, you may damage the VFD as well as the option unit.

2.3 Mounting Procedure



HAZARDOUS VOLTAGE PRESENT

Always isolate power from the VFD and wait 10 minutes until the bus charge light is off and check for residual before inserting or removing this option unit or touching the terminals.

2. Make sure the VFD line power is off and the charge light on the VFD shows that the VFD is not storing an electrical charge. Refer to the VFD instruction manual if necessary. You may damage the option unit if you install it with the line power connected.
3. Insert this option unit into one of the VFD's option ports by Carefully inserting the connector of the option unit into the connector of the VFD. Use the two mounting holes and the guide hole to align the option with the matching machine screw inserts and the plastic guide pin on the VFD. Make sure that the FR-A5AN option is firmly seated in the VFD and the connector is fully plugged in.
4. Secure the option unit to the VFD with two mounting screws. If the screw holes in the option unit do not line up with the VFD mounting holes, check that the connectors have been fitted correctly.

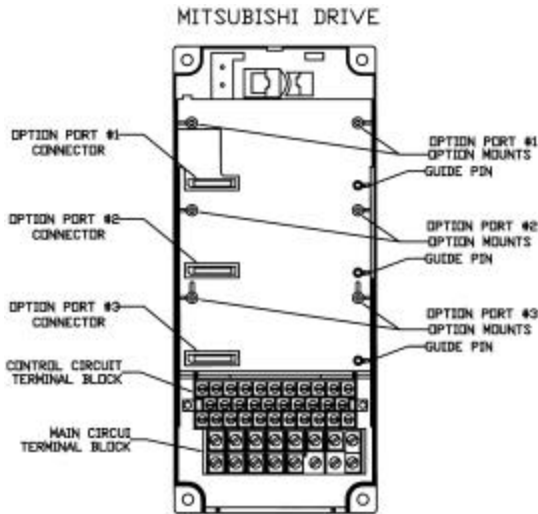

Figure 4: Drive View

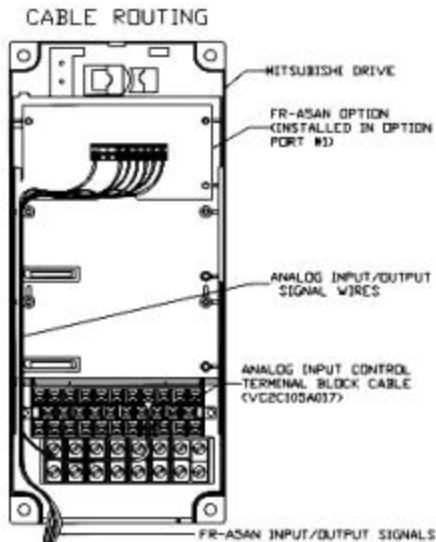

Figure 5: Cable Routing View

- Route the analog input & output signal cables along the side of the VFD case as shown in

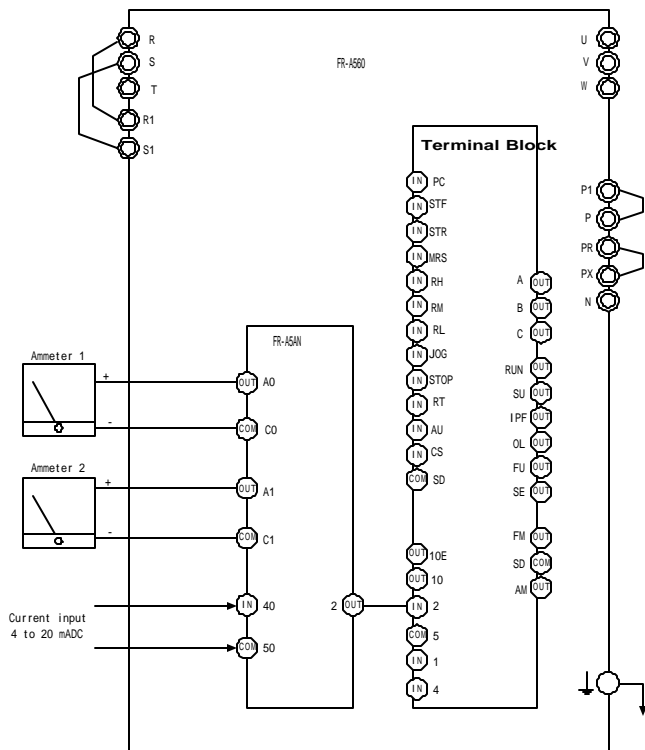

figure 4.

Figure 6: Wiring Diagram

- When installing the option be sure to follow local electrical codes concerning proper wire gauge and circuit protection.
- All external signals are connected to the option through the options terminal block labeled for signal Identification. The terminal block is UL & CSA approved for 28-16 AWG wire.

8. The 1 analog input is located at terminals 40 & 50 with 40 as the positive and 50 as the negative. The corresponding isolated output is terminal 2 and is made to be connected directly to the VFD terminal block control input terminal #2 with the cable VC2C105A017 included with the option.
9. The options analog output signals are connected to terminals A0 & C0 (channel 1) and A1 & C1 (channel 2). A0 and A1 are positive output terminals to the FR-A5AN option, while C0 & C1 are the negative terminals.
10. Next replace the VFD cover, while making sure that the signal wires are not caught or pinched between the cover and the chassis.
11. Set and calibrate all relevant parameters before running the VFD.

3. FR-A5AN Operation

The operation of the A560 VFD does not change when you install the FR-A5AN option unit. The option has two features, 1 analog input and 2 VFD driven analog outputs. The 1 analog input signal is used with the VFD's terminal block to enter an analog value that will control the VFD's running frequency. The 2 VFD driven analog output signals are driven by the user selectable set VFD function.

3.1 Analog Input/Output Terminals

The FR-A5AN analog input terminals, 40, 50, & 2 are used for the analog input function. Terminals A0,C0, A1, & C1 are used for the analog output function.

2	Analog VFD control signal	FR-A5AN Output signal to terminal 2 of the VFD control signal terminal block. (Use Cable VC2C105A017)
40, 50	Analog input signal	Terminal 40 is for the positive connection, and terminal 50 is for the common connection of the analog input signal.
A0, C0, A1, C1	Analog output signals.	Output signals A0, C0 (channel 1) and A1, C1 (channel 2) will output an analog current corresponding to the function set by the user. A0 & A1 are the current output terminals and C0 & C1 are the common terminals.

Table 2: FR-A5AN I/O Terminal Description

3.1.1 Operating Functions

The FR-A5AN has two basic function's, an analog input function and an analog output function. These two functions can be used independently or concurrently. The 4-20 mA analog output functions are user selectable and can represent one of several VFD functions. The 4-20 mA analog input function is designed to control the VFD's running speed by way of the VFD's control signal terminal block. The FR-A5AN option will only function with the proper drive firmware as described on page 11 of this manual.

3.1.2 VFD terminal block control input terminals

1. When an analog input signal is passed into the FR-A5AN option through terminals 40 & 50 and the options #2 terminal is connected to the #2 terminal of the VFD's control signal terminal block, with cable VC2C105A017, the VFD's running frequency can be set form the input current. The FR-A5AN current input can be adjusted using the procedure listed on page 22 of this manual

3.1.3 User Selectable Analog Input/Output Values

The Input and output full scale value can be set by the user using the VFD parameters listed in table 3. The analog outputs from the FR-A5AN can also be set to represent one of several functions of the VFD listed in table 5.

3.1.4 Parameter Functions

The following parameters are used to change the FR-A5AN functionality. The parameters listed below can be changed by the user to calibrate the analog values input and output form the FR-A5AN. The following parameters are also used to set the analog outputs function. The valid parameters for this option are 306-312 & 900-903.

Parameter Number	Setting Range	Factory Setting	Parameter Function
306	1 ~ 24	2	Analog output signal selection channel #2
307	0 ~ 100%	0 %	Current output setting for zero output channel #2
308	0 ~ 100%	100 %	Current output setting for maximum output channel #2
309	0,1,10,11	1	Analog output signal selection
310	1 ~ 24	2	Analog output signal selection channel #1
311	0 ~ 100%	0 %	Current output setting for zero output channel #1
312	0 ~ 100%	100 %	Current output setting for maximum output channel #1
Parameter Number	Factory Setting	Parameter Function	
900	N/A	Analog output signal tuning channel #1	
901	N/A	Analog output signal tuning channel #2	
902	0 Volts	Drive input current setting for 0% current from the FR-A5AN option (terminal #2)	
903	5 Volts	Drive input current setting for 100 % current from the FR-A5AN option (terminal #2)	

Table 3: Input/Output Signal Parameters

3.1.5 Parameter Settings

Use the following list for parameter settings.

Factory Setting = 2	Parameter #: 306
Function: Analog output signal selection for channel #2, terminals A1 & C1	
Setting Range: 1 ~ 24	
Increment: 1	
Remarks: 4,15,16,19,20,22,23, are invalid and must not be set.	
Relevant Parameters:	

Factory Setting = 0%	Parameter #: 307
Function: Analog output setting for zero analog input, channel #2, terminals A1 & C1	
Setting Range: 0 ~ 100%	
Increment: 0.1%	
Remarks:	
Relevant Parameters:	

Factory Setting = 100%	Parameter #: 308
Function: Analog output setting for maximum analog input, channel #2, terminals A1 & C1	
Setting Range: 0 ~ 100%	
Increment: 0.1%	
Remarks:	
Relevant Parameters:	

Factory Setting = 0	Parameter #: 309
Function: Analog output signal switching channel #1 & channel #2	
Setting Range: 0, 1, 10, 11	
Increment: 1	
Remarks:	
Relevant Parameters:	
Factory Setting = 2	Parameter #: 310
Function: Analog output signal selection for channel #1, terminals A0 & C0	
Setting Range: 1 ~ 24	
Increment: 1	
Remarks: 4,15,16,19,20,22,23, invalid & must not be set.	
Relevant Parameters:	
Factory Setting = 0%	Parameter #: 311
Function: Analog output setting for zero analog input, channel #1, terminals A0 & C0	
Setting Range: 0 ~ 100%	
Increment: 0.1%	
Remarks:	
Relevant Parameters:	
Factory Setting = 100 %	Parameter #: 312
Function: Analog output setting for maximum analog input, channel #1, terminals A0 & C0	
Setting Range: 0 ~ 100%	
Increment: 0.1%	
Remarks:	
Relevant Parameters:	

Table 4: Control Signal Parameter Settings

3.2 Analog Output Selection Signal

The FR-A5AN analog output can be used to select any one of several VFD functions. When a FR-A5AN and a FR-A5AY are both installed, priority is given to the FR-A5AN option. The value set in parameters 306 & 310 select the function that will be output as an analog signal to channels 1 & 2. It should be noted that when the same function is used for both channel 1 & 2, (parameter 309 = 0 or 10) the function is set by parameter 306 and parameter 310 does not need to be set and is ignored by the VFD.

Parameter Value	Signal Definition	Unit	Full Scale Value
1	Output Frequency	Hz	Value set in parameter 55
2	Output Current	A	Value set in parameter 56
3	Output Voltage	V	965 Volts
5	Frequency Set Value	Hz	Value set in parameter 55
6	Running Speed	Rpm	The value is converted from the parameter 55 value by the parameter 37 value
7	Motor Torque (Note 1)	%	Rated torque of the applied motor x 2
8	Converter Output Voltage	V	965 Volts
9	Regenerative Brake Duty	%	Value set in parameter 70

Parameter Value	Signal Definition	Unit	Full Scale Value
10	Electronic Over Current Protection Load Factor	%	Over current protection level
11	Output Current Peak Value	A	Value set in parameter 56
12	Converter Output Peak Value	V	965 Volts
13	Input Power	kW	Rated power of the VFD r x 2
14	Output Power	kW	Rated power of the VFD r x 2
17	Load Meter	%	Value set in parameter 56
18	Motor Excitation Current	A	Value set in parameter 56
21	Reference Voltage Output	-	Full scale voltage or current is output to terminal A0 or A1
24	Motor Load Factor	kW	Rated VFD current x 2

Table 5: Output Selection Signal Settings

(Note 1) The motor torque is only valid when magnetic flux vector control has been selected in the VFD. The rated torque of the applied motor is calculated from the settings of the magnetic flux vector control parameters.

(Note 2) If an VFD alarm occurs terminals A0 and A1 keep outputting the selected signals.

3.3 Analog Output Setting for Zero Input and Maximum Input

The FR-A5AN analog output can be offset to allow for a input value of zero to represent any current up to the maximum current output. This value is set in parameters 307 (channel 2) and 311 (channel 1). An example of this would be if a zero value such as 0 Hz would have a current output of 4 mA.

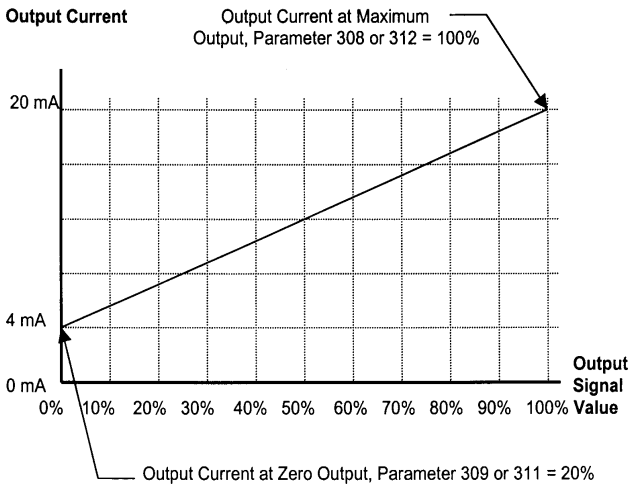

Figure 7: Output Graph

3.4 Analog Output Signal Switching for Channel 1 & 2

The FR-A5AN analog output can have the same or different signals sent to channel 1 & 2. This selection is set with parameter 309.

Parameter 309 Value	Description	Parameters Used for Settings
0	The same function is output on channels 1 and 2 of the FR-A5AN	Channel 1 and 2: Parameter 306: Signal selection Parameter 307: Analog output setting for zero input signal. Parameter 308: Analog output setting for maximum input signal
10		
1	Different functions are output on channels 1 and 2 of the FR-A5AN	Channel 2: Parameter 306: Signal selection Parameter 307: Analog output setting for zero input signal Parameter 308: Analog output setting for maximum input signal
11		Channel 1: Parameter 310: Signal selection Parameter 311: Analog output setting for zero input signal Parameter 312: Analog output setting for maximum input signal

Table 6: Signal Switching Channel 1 & 2 Settings

3.5 FR-A5AN analog Output Calibration

The FR-A5AN analog outputs should be calibrated (fine tuned) following the procedure outlined below.

Calibrating the analog outputs for channel 1 & 2 is done differently, and depends on the value set in parameter 309. If the same function is being output to channels 1 & 2 parameter 901 is used. If different functions are being output to channels 1 & 2 parameters 900 and 901 will be used.

3.5.1 Calibration When Parameter 309=0 or 10

First set the analog output signal selection, parameter 306, to a value of 21. At this point the FR-A5AN should output approximately 20 mA. Next run the VFD to the full set speed, 60 Hz or greater is recommended to ensure a significant swing in the analog output. The next step is to set parameter 901, when the parameter unit displays this parameter use the Up/Down arrow keys to adjust the FR-A5AN analog output to the desired current. When the proper meter deflection or current output is achieved, press the write key on the parameter unit to set the value. The last step is to set parameter 306 to the VFD function you would like output on channels 1 and 2 of the FR-A5AN option (see table 5 on page 24 of this manual).

3.5.2 Calibration When Parameter 309=1 or 11

Channel 1: First set the analog output signal selection, parameter 310, to a value of 21. At this point the FR-A5AN (A0 & C0) should output approximately 20 mA. Next run the VFD to the full set speed, 60 Hz or greater is recommended to ensure a significant swing in the analog output. The next step is to set parameter 900, when the parameter unit displays this parameter use the Up/Down arrow keys to calibrate the FR-A5AN current output. When the proper meter deflection or current output is achieved, press the write key on the parameter unit to set the value. The last step is to set parameter 310 to the VFD function you would like output on channel 1 of the FR-A5AN option (see table 5 on page 24 of this manual).

Channel 2: First set the analog output signal selection, parameter 306, to a value of 21. At this point the FR-A5AN (A1 & C1) should output approximately 20 mA. Next run the VFD to the full set speed, 60 Hz or greater is recommended to ensure a significant swing in the analog output. The next step is to set parameter 901, when the parameter unit displays this parameter use the Up/Down arrow keys to calibrate the FR-A5AN current output. When the proper meter deflection or current output is achieved, press the write key on the parameter unit to set the value. The last step is to set parameter 306 to the VFD function you would like output on channel 2 of the FR-A5AN option (see table 5 on page 24 of this manual).

3.6 FR-A5AN analog Input Calibration

The FR-A5AN analog inputs should be calibrated (fine tuned) following the procedure outlined below. Calibrating the analog input from the signal connected to terminals 40, 50, and 2 is done differently. First set the FR-A5AN analog input current for a zero running frequency. Next set parameter 902 by pressing the read key twice and then pressing the write key twice. Now set the FR-A5AN analog input current for the required maximum running frequency. Next set parameter 903 by pressing the read key twice and then the write key twice. The Fr-A5AN analog input current is now calibrated.

4. FR-A5AN Specifications

1. Output signals
 - Across terminals A0-C0: 4-20 mA
 - Across terminals A1-C1: 4-20 mA
 2. Output resolution 1 μ A
 3. Display accuracy (reference value)
 - $\pm 10\%$ of the full scale output value
 - This value depends on the output signal type
 4. Meters used
 - DC ammeter full scale 20 mA
 - (internal impedance 100 Ω or less)
 5. Maximum cable length 10 meters
 6. Operating Temperature $-10^{\circ} \sim 50^{\circ}$ C
 7. Storage Temperature(1) $-20^{\circ} \sim 56^{\circ}$ C
 8. Relative Humidity $\leq 90\%$ @ 50° C, non-condensing.
 9. Dimensions 96 x 49 x 18 mm
- (1) This refers to a short period of time such as during transportation.

5. References

Mitsubishi Electric

FR-A560(L) VFD Instruction Manual

Technical Support Number

800-950-7781

6. Revisions

Print Date	Manual Number	Revision
May 2000	VC2BNA000028	Original Version

7. User Note's Section

Mitsubishi VFD Instruction Manual
FR-A5AN

2000 Mitsubishi Electric Automation, Inc.