

FX_{2N}

FX_{2N}-4DA SPECIAL FUNCTION BLOCK

USER'S GUIDE

JY992D65901A

This manual contains text, diagrams and explanations which will guide the reader in the correct installation and operation of the FX_{2N}-4DA special function block and should be read and understood before attempting to install or use the unit.

Further information can be found in the FX PROGRAMMING MANUAL, FX_{2N} SERIES HARDWARE MANUAL .

1 INTRODUCTION

- The FX_{2N}-4DA analog special function block has four output channels. The output channels take a digital value and output an equivalent analog signal. This is called a D/A conversion. The FX_{2N}-4DA has maximum resolution of 12 bits.
- The selection of voltage or current based input/output is by user wiring. Analog ranges of -10 to 10V DC (resolution: 5mV), and/or 0 to 20mA (resolution: 20μA) maybe selected independently for each channel.
- Data transfer between the FX_{2N}-4DA and the FX_{2N} main unit is by buffer memory exchange. There are 32 buffer memories (each of 16 bits) in the FX_{2N}-4DA.
- The FX_{2N}-4DA occupies 8 points of I/O on the FX_{2N} expansion bus. The 8 points can be allocated from either inputs or outputs. The FX_{2N}-4DA draws 30mA from the 5V rail of the FX_{2N} main unit or powered extension unit.

2 EXTERNAL DIMENSIONS AND PARTS

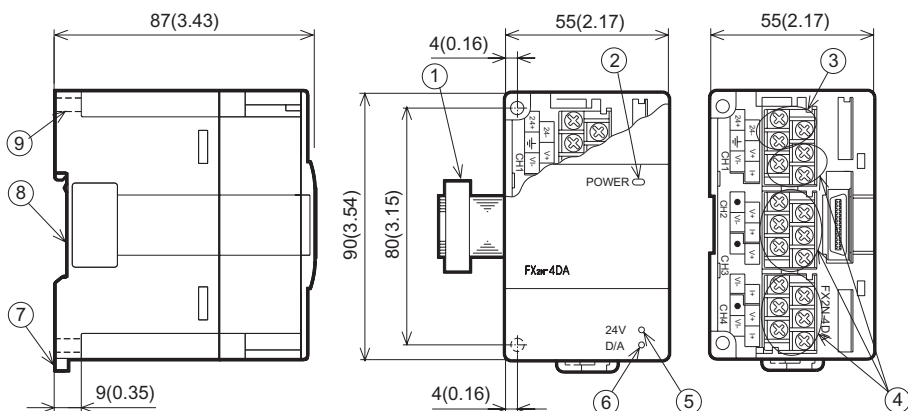

● Weight : Approx. 0.3 kg (0.66 lbs)

- ① Extension cable
- ② Power indicator lamp (LED)
5 V power is supplied from the programmable controller to light this indicator lamp.
- ③ Power supply terminals
(Screw terminal: M3 (0.12))
- ④ Analog output terminals
(Screw terminals : M3 (0.12))

● Accessory: Special block number label

- ⑤ 24 V power indicator lamp (LED)
24 VDC power is supplied to the terminals of the FX_{2N}-4DA to light this indicator lamp.
- ⑥ D/A conversion indicator lamp (LED)
Flashes at a high speed if D/A conversion is performing without a problem.
- ⑦ Hook for DIN rail
- ⑧ Groove for DIN rail mounting
(Width of DIN rail : 35 mm 1.38")
- ⑨ Hole for direct mounting (2-φ4.5) (0.18)

Handling of crimp-style terminal

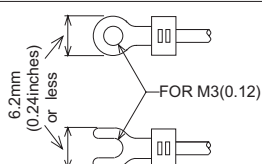

- Be sure to use the crimp-style terminals that satisfy the dimensional requirements shown in the left figure.
- Apply 0.5 to 0.8 N-m (5 to 8 kgf-cm) torque to tighten the terminals. Firmly tighten the terminals to prevent abnormal operation.

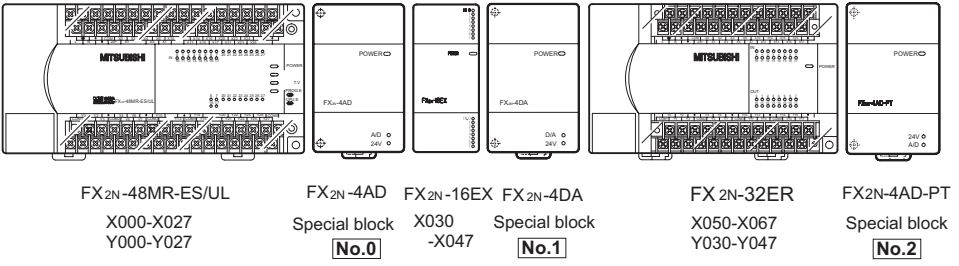

CONNECTION TO PROGRAMMABLE CONTROLLER

Various special blocks controlled by the FROM/TO commands, such as the analog input blocks high-speed counter blocks, etc. can be connected to the FX2N programmable controller (MPU), or connected to the right side of the other extension blocks or units. Up to eight special blocks can be connected to a single MPU in the numeric order of No. 0 to No. 7.

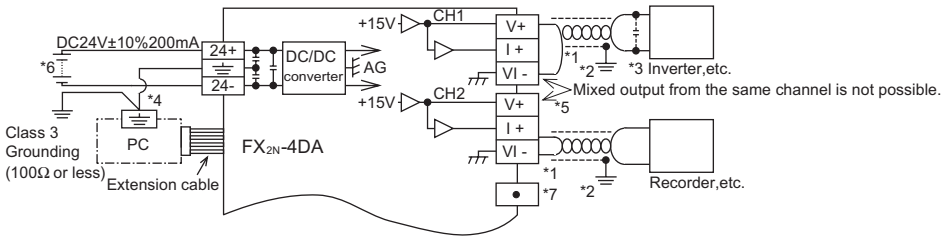

WIRING: The terminal layout shown below may differ from the actual layout. For the correct terminal layout, refer to section 2 External Dimensions and Parts.



- *1: Use a twisted pair shielded cable for the analog output. This cable should be wired away from power lines or any other lines which could induce noise.
- *2: Apply 1-point grounding at the load side of the output cable (class 3 grounding: 100Ω or less).
- *3: If electrical noise or a voltage ripple exists at the output, connect a smoothing capacitor of 0.1 to 0.47μF, 25V.
- *4: Connect the  terminal on the FX2N-4DA with the  terminal on the MPU of the programmable controller.
- *5: Shorting the voltage output terminal or connecting the current output load to the voltage output terminal may damage the FX2N-4DA.
- *6: The 24V DC service power of the programmable controller can also be used.
- *7: Do not connect any unit to the unused terminal .

ENVIRONMENTAL SPECIFICATIONS

Item	Specification
Environmental specifications (excluding following)	Same as those for the FX2N main unit
Dielectric withstand voltage	500V AC, 1min (between all terminals and ground)

PERFORMANCE SPECIFICATIONS

Item	Voltage output	Current output
Analog output range	-10V DC to +10V DC (External load resistance: 2kΩ to 1MΩ).	DC 0mA to +20mA (External load resistance: 500Ω).
Digital input	16 bits, binary, with sign (Effective bits for numeric value: 11 bits and sign bit (1 bit))	
Resolution	5mV (10V × 1/2000)	20μA (20mA × 1/1000)
Total accuracy	±1% (at full scale of +10V)	±1% (at full scale of +20mA)
Conversion speed	2.1ms for 4 channels (Change in the number of channels used will not change the conversion speed.)	
Isolation	Photo-coupler isolation between analog and digital circuits. DC/DC converter isolation of power from FX2N main unit. No isolation between analog channels.	
External power supply	24V DC ±10% 200mA	
Number of occupied I/O points	8 points taken from the FX2N expansion bus (can be either inputs or outputs)	
Power consumption	5V, 30mA (Internal power supply from MPU or powered extension unit)	

I/O characteristics
(Default: mode 0)
Follow the procedure described in section 8 to change

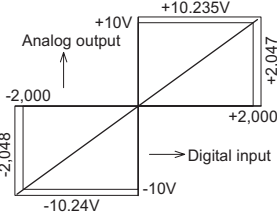

Command sent from the programmable controller can change the mode. The voltage/current output mode selected will determine the output terminals used.

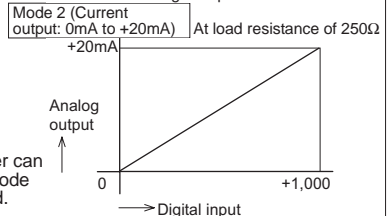
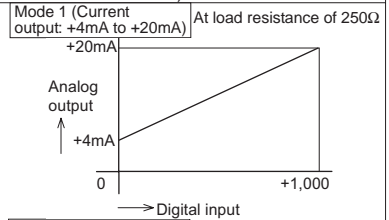

ALLOCATION OF BUFFER MEMORIES (BFM)

Data is transmitted between the FX_{2N}-4DA and the MPU via buffer memories (16-bit 32-point RAM).

BFM	Description
#0 E	Output mode select. Factory setting H0000
#1	Output data (Signed 16 bits binary: actual value 11 bits + sign) #1: CH1, #2: CH2, #3: CH3, #4: CH4
#2	
#3	
#4	
#5 E	Data holding mode. Factory setting H0000
#6, #7	Reserved

Buffer memories marked "W" can be written to using the T0 instruction in the MPU.

The status of BFM #0, #5, and #21, (marked E) will be written to EEPROM, therefore the set values will be retained even after turning off the power.

- ① [BFM #0] Output mode select: The value of BFM #0 switches the analog output between voltage and current on each channel. It takes the form of a 4 digit hexadecimal number. The first digit will be the command for channel 1 (CH1), and the second digit for channel 2 (CH2) etc. The numeric values of these four digits respectively represent the following items:



- O = 0: Sets the voltage output mode (-10 V to +10 V).
O = 1: Sets the current output mode (+4 mA to 20 mA).
O = 2: Sets the current output mode (0 mA to +20 mA).

Switching the output mode resets the I/O characteristics to the factory-set characteristics. Refer to the performance specifications described in section 4.

Example: H2110 CH1 : Voltage output (-10 V to +10 V)
CH2 and CH3 : Current output (+4 mA to +20 mA)
CH4 : Current output (0 mA to +20 mA)

- ② [BFM #1, #2, #3 and #4]: Output data channels CH1, CH2, CH3, and CH4
BFM #1: Output data of CH1 (Initial value: 0) BFM #2: Output data of CH2 (Initial value: 0)
BFM #3: Output data of CH3 (Initial value: 0) BFM #4: Output data of CH4 (Initial value: 0)

- ③ [BFM #5]: Data holding mode: While the programmable controller is in the STOP mode, the last output value in the RUN mode will be held. To reset the value to the offset value, write the hexadecimal value in BFM #5 as follows:



- O = 0: Holds the output.
O = 1: Resets to the offset value.

Example: H0011 CH1 and CH2 = Offset value CH3 and CH4 = Output holding

In addition to the above functions, the buffer memories can adjust the I/O characteristics of the FX_{2N}-4DA, and report the status of the FX_{2N}-4DA to the programmable controller.

BFM	Description
#8(E)	Offset/gain setting command CH1, CH2 Initial value H0000
#9(E)	Offset/gain setting command CH3, CH4 Initial value H0000
#10	Offset data CH1 *1
#11	Gain data CH1 *2
#12	Offset data CH2 *1
#13	Gain data CH2 *2
#14	Offset data CH3 *1
#15	Gain data CH3 *2
#16	Offset data CH4 *1
#17	Gain data CH4 *2
#18, #19	Reserved
#20(E)	Initialize. initial value = 0
#21 E	I/O characteristics adjustment inhibit (Initial value 1)
#22-#28	Reserved
#29	Error status
#30	K3020 identification code
#31	Reserved

Buffer memories marked "W" can be written to using the T0 instruction in the MPU. The status of BFM #0, #5, and #21, (marked E) will be written to EEPROM, therefore the set values will be retained even after turning off the power.

*1: Offset data: Actual analog output value when corresponding output data (BFM #1 through #4) is 0
*2: Gain data: Actual analog output value when corresponding output data (BFM #1 through #4) is +1,000

*3: When current output mode 1 (+4 mA to +20 mA) is set, the offset data will be automatically set to +4,000 and the gain data to +20,000. When the current output mode 2 (0 mA to +20 mA) is set, the offset data will be automatically set to 0 and the gain data to +20,000.

- ④ [BFM #8 and #9] Offset/gain setting command: Changes offset and gain values of channels CH1 through CH4 by writing 1 to the corresponding Hex digits of BFM #8 or #9. The current values will be valid until this command is output.

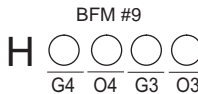
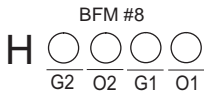

- O = 0: No changes done.
O = 1: Change data value.

(Program example : see section 8.)

- ⑤ [BFM #10 through #17] Offset/gain data: The offset and gain values are changed by writing new data to BFM #10 through #17. The units of the data to be written is mV or μ A. The data should be written and then BFM #8 and #9 set. Note that the data value will be rounded down to the nearest 5mV or 20 μ A.

- ⑥ [BFM #20] Initialize: When K1 is written in BFM #20, all values will be initialized to the factory-settings. (Note that the BFM #20 data will override the BFM #21 data.) This initialize function is convenient if you have an error in adjustment.

- ⑦ [BFM #21] I/O characteristics adjustment inhibit: Setting BFM #21 to 2 inhibits the user from inadvertent adjustment of I/O characteristics. The adjustment inhibit function, once set, will be valid until the Permit command (BFM #21=1) is set. The initial value is 1 (Permit). The set value will be retained even after power-off.

⑧ [BFM #29] Error status: When an error occurs, use the FROM command to read out the details of the error.

Bit	Name	Status when bit is set to "1" (turned on)	Status when bit is set to "0" (turned off)
b0	Error	Error if any of b1 through b4 is turned on	No error
b1	O/G error	Offset/gain data in EEPROM is abnormal or a data setting error occurs.	Offset/Gain data normal
b2	Power supply error	24V DC power failure	Power supplied normally
b3	Hardware error	Defective D/A converter or other hardware	Non-detective hardware
b10	Range error	The digital input or analog output value is out of the specified range.	The input or output value is in the specified range.
b12	G/O-Adjustment prohibit status	BFM #21 is not set to "1".	Adjustable status (BFM #21 = 1)

Bits b4 through b9, b11, b13 through b15 are not defined.

⑨ [BFM #30]The identification code for a special block is read using the FROM command.The identification code for the FX_{2N}-4DA unit is K3020.The MPU can use this facility in the program to identify the special block before commencing any data transfer from and to the special block.

Note : BFM #'s marked E(E).

- Values of BFM #0, #5, and #21, (marked E) are stored in EEPROM memory of the FX_{2N}-4DA. BFM #10 to #17 are copied to EEPROM when the gain/offset setting command BFM #8, #9 is used. Also, BFM #20 causes resetting of the EEPROM memory. The EEPROM has a life of about 10,000 cycles (changes), so do not use programs which frequently change these BFM's.
- A mode change of BFM #0 automatically involves a change of the corresponding offset and gain values. Because of the time needed to write the new values to the internal EEPROM memory, a delay of 3 s is required between instructions changing BFM #0 and instructions writing to the corresponding BFM #10 through BFM #17. Therefore, a delay timer should be used before writing to BFM #10 through #17.

6 OPERATION AND PROGRAM EXAMPLES

If the factory-set I/O characteristics are not changed and the status information is not used, you can operate the FX_{2N}-4DA using the following simple program. For the FROM and TO commands, refer to the FX Programming Manual.

CH1 and CH2: Voltage output mode (-10 V to +10 V)
 CH3: Current output mode (+4 mA to +20 mA)
 CH4: Current output mode (0 mA to +20 mA)

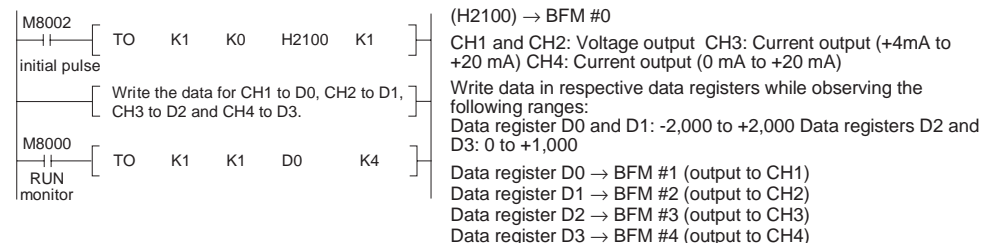

Operation procedure

- ① Turn off the power of the MPU, and then connect the FX_{2N}-4DA. After that, wire the I/O lines of the FX_{2N}-4DA.
- ② Set the MPU to STOP, and turn on the power. Write the above program then switch the MPU to RUN.
- ③ Analog values will be sent from D0 (BFM #1), D1 (BFM #2), D2 (BFM #3), and D3 (BFM #4) to the respective output channels of the FX_{2N}-4DA. When the MPU is in STOP, the analog values set before stopping the MPU will remain output. (The output will be held.)
- ④ When the MPU is in STOP, the offset values can also be output. For a detailed description, refer to Section 5, ③.

Program example

For the following program, CH1 and CH2 of the FX_{2N}-4DA connected at special block position No. 1 are used as voltage output channels, CH3 as a current output channel (+4 mA to +20 mA), and CH4 as a current output channel (0 mA to +20 mA). When the MPU is in STOP, the output will be held. In addition, the status information is used.

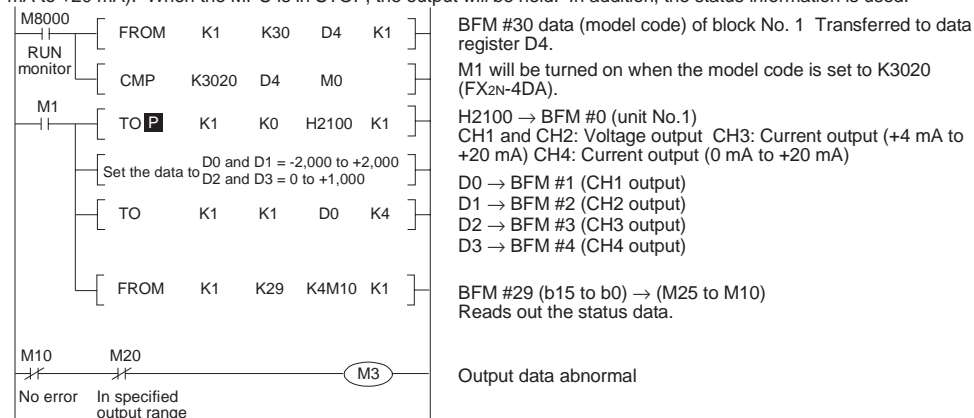

- ① Check whether the output wiring and/or expansion cables are properly connected on FX_{2N}-4DA analog special function block.
- ② Check that the FX_{2N} system configuration rules have not been broken, i.e. the number of blocks does not exceed 8 and the total system I/O is equal or less than 256 I/O.
- ③ Ensure that the correct output mode has been selected for the application.
- ④ Check that there is no power overload on either the 5V or 24V power source, remember the loading on the FX_{2N} MPU or a powered extension unit varies according to the number of extension blocks or special function blocks connected.
- ⑤ Put the main processing unit into RUN.
- ⑥ After turning on or off the 24 VDC power for analog signals, the analog output may fluctuate for approximately 1 second. This is due to time delays in the power supply from the MPU or differences in start time. For this reason, be sure to take preventive measures so that this output fluctuation will not affect the external units.

[Example of preventive measure]

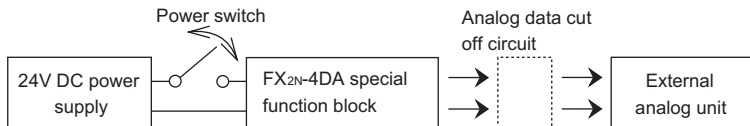

I/O characteristics

The standard characteristics (factory default) are shown by the solid lines in the figure below. These characteristics can be adjusted according to the conditions of the user's system.

Standard characteristics of voltage output

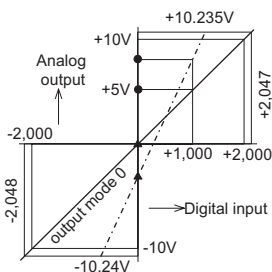

Standard characteristics of current output (+4mA to +20mA)

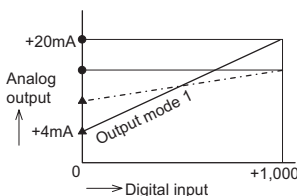

Standard characteristics of current output (0mA to +20mA)

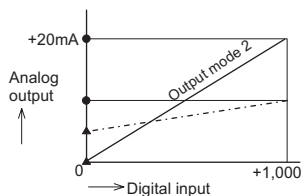

- . . . Gain value : Analog output value when the digital input is +1,000
- ▲ . . . Offset value : Analog output value when the digital input is 0

When the slope of the I/O characteristic line is steep: Slight changes to the digital input will greatly increase or reduce the analog output.

When the slope of the I/O characteristic line is gentle: Slight changes to the digital input will not always change the analog output.

Note that the resolution (minimum possible change of analog output) of the FX_{2N}-4DA is fixed.

Adjustment of I/O Characteristics

To adjust the I/O characteristics, set the offset and gain of the FX_{2N}-4DA either using push button switches connected to input terminals of the programmable controller or using the forced on/off function of a programming panel. To change the offset and gain, just change the conversion constants of the FX_{2N}-4DA. Metering of the analog output is not needed for adjustment, however a program should be created in the MPU.

An example program for adjustment is shown below. The example shows that for channel CH2 of FX_{2N}-4DA block No. 1, the offset value is changed to 7 mA, and the gain value to 20 mA. Note that for CH1, CH3, and CH4, the standard voltage output characteristics are set.

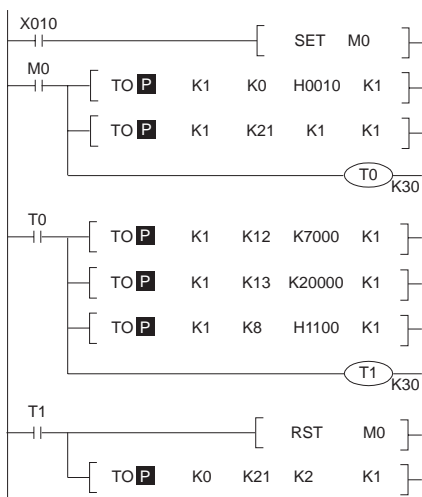

OPERATION START

(H0010)→BFM#0 Sets the mode of the output channel.
(K1)→BFM#21 Permits adjustment of I/O characteristics.

(K7000)→BFM#12 Sets the offset data. (Offset value: 7 mA)

(K20000)→BFM#13 Sets the gain data. (Gain value: 20 mA)

(H1100)→BFM#8 CH2 offset/gain setting command

OPERATION END

(K2)→BFM#21 Inhibits adjustment of I/O characteristics

After adjustment, the I/O characteristics will be as follows

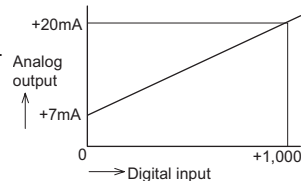

Outline of FROM and TO commands: For a detailed description, refer to the FX Programming Manual.

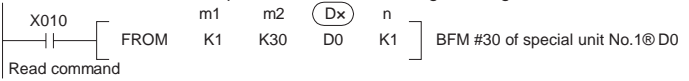
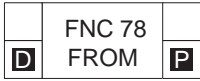

Read BFM

m1 : Special unit or block number (K0 to K7, numbered from the MPU)

m2 : Buffer memory head address (K0 to K31)

(D) : Head device number of destination data. T, C, D, KnM, KnY, KnS, V, and Z can be used to designate the head device. Each device number can be qualified using an index.

n : Number of transfer points (K1 to K32) (K1 to K16 for 32-bit command)

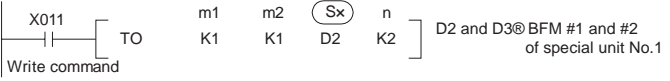
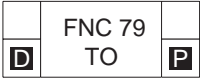

Write BFM

m1,m2,n: Same as above

(S) : Head device number of source data. T, C, D, KnX, KnM, KnY, KnS, V, Z, K, and H can be used to designate the head device. Each device number can be qualified using an index.

- When X010 and X011 are off, transfer will not be executed, therefore the destination data value will not be changed.

9 TROUBLESHOOTING

If the FX2N-4DA does not operate properly, check the following items

- ① Check the external wiring. Refer to section 3 of this manual.
- ② Check status of the POWER indicator lamp (LED) of the FX2N-4DA.
On : The extension cable is properly connected.
Off or flash : Check connection of extension cable. Also check the 5 V power supply capacity.
- ③ Check status of the 24 V power indicator lamp (LED) of the FX2N-4DA.
On : 24 VDC is supplied.
Off : Supply 24 VDC (+10%) to the FX2N-4DA.
- ④ Check the status of the D/A conversion indicator lamp (LED) of the FX2N-4DA.
Flash : D/A conversion is normal.
On or off : The ambient conditions are not suitable for the FX2N-4DA, or the FX2N-4DA is defective.
- ⑤ Check that the external load resistance connected to each analog output terminal does not exceed the capacity of the FX2N-4DA drive (voltage output: 2kΩ to 1 MΩ / current output: 500Ω).
- ⑥ Check the output voltage or current value using a voltmeter or ammeter, and confirm that the output meets the I/O characteristics. If the output does not meet the I/O characteristics, adjust the offset and gain again. Refer to section 8.

Note

To test the withstand voltage of the FX2N-4DA, connect all the terminals to the grounding terminal.

Guidelines for the safety of the user and protection of the FX2N-4DA special function block

- This manual has been written to be used by trained and competent personnel. This is defined by the European directives for machinery, low voltage and EMC.
- If in doubt at any stage during the installation of the FX2N-4DA always consult a professional electrical engineer who is qualified and trained to the local and national standards. If in doubt about the operation or use of the FX2N-4DA please consult the nearest Mitsubishi Electric distributor.
- Under no circumstances will Mitsubishi Electric be liable or responsible for any consequential damage that may arise as a result of the installation or use of this equipment.
- All examples and diagrams shown in this manual are intended only as an aid to understanding the text, not to guarantee operation. Mitsubishi Electric will accept no responsibility for actual use of the product based on these illustrative examples.

Manual number : JY992D65901

Manual revision : A

Date : JUNE 1997

MITSUBISHI ELECTRIC CORPORATION

HEAD OFFICE: MITSUBISHI DENKI BLDG MARUNOUCHI TOKYO 100 TELEX: J24532 CABLE MELCO TOKYO
HIMEJI WORKS: 840, CHIYODA CHO, HIMEJI, JAPAN

FX_{2N}

FX_{2N}-4DA SPECIAL FUNCTION BLOCK USER'S GUIDE

JY992D65901A

This manual contains text, diagrams and explanations which will guide the reader in the correct installation and operation of the FX_{2N}-4DA special function block and should be read and understood before attempting to install or use the unit.
Further information can be found in the FX PROGRAMMING MANUAL, FX_{2N} SERIES HARDWARE MANUAL.

1 INTRODUCTION

- The FX_{2N}-4DA analog special function block has four output channels. The output channels take a digital value and output an equivalent analog signal. This is called a D/A conversion. The FX_{2N}-4DA has maximum resolution of 12 bits.
- The selection of voltage or current based input/output is by user wiring. Analog ranges of -10 to 10V DC (resolution: 5mV), and/or 0 to 20mA (resolution: 20μA) may be selected independently for each channel.
- Data transfer between the FX_{2N}-4DA and the FX_{2N} main unit is by buffer memory exchange. There are 32 buffer memories (each of 16 bits) in the FX_{2N}-4DA.
- The FX_{2N}-4DA occupies 8 points of I/O on the FX_{2N} expansion bus. The 8 points can be allocated from either inputs or outputs. The FX_{2N}-4DA draws 30mA from the 5V rail of the FX_{2N} main unit or powered extension unit.

2 EXTERNAL DIMENSIONS AND PARTS

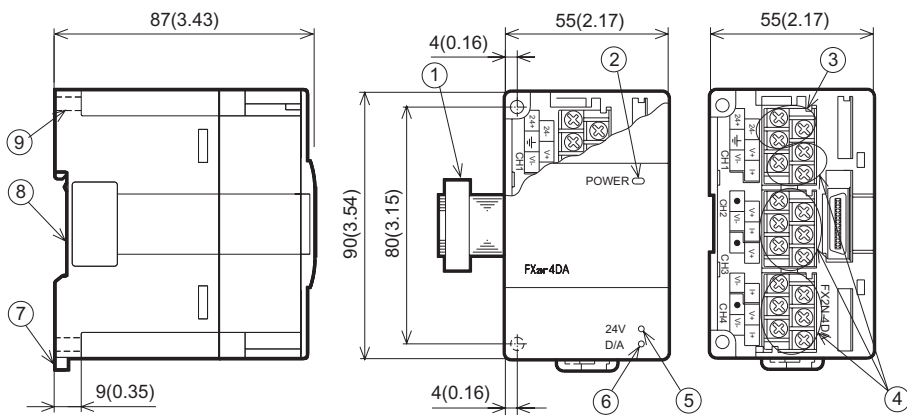

● Weight : Approx. 0.3 kg (0.66 lbs)

- Extension cable
- Power indicator lamp (LED)
5 V power is supplied from the programmable controller to light this indicator lamp.
- Power supply terminals
(Screw terminal: M3 (0.12))
- Analog output terminals
(Screw terminals : M3 (0.12))

● Accessory: Special block number label

- 24 V power indicator lamp (LED)
24 VDC power is supplied to the terminals of the FX_{2N}-4DA to light this indicator lamp.
- D/A conversion indicator lamp (LED)
Flashes at a high speed if D/A conversion is performing without a problem.
- Hook for DIN rail
- Groove for DIN rail mounting
(Width of DIN rail : 35 mm 1.38")
- Hole for direct mounting (2-φ4.5) (0.18)

Handling of crimp-style terminal

- Be sure to use the crimp-style terminals that satisfy the dimensional requirements shown in the left figure.
- Apply 0.5 to 0.8 N·m (5 to 8 kgf·cm) torque to tighten the terminals. Firmly tighten the terminals to prevent abnormal operation.

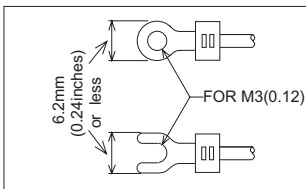

3 INSTALLATION AND WIRING

CONNECTION TO PROGRAMMABLE CONTROLLER

Various special blocks controlled by the FROM/TO commands, such as the analog input blocks high-speed counter blocks, etc. can be connected to the FX_{2N} programmable controller (MPU), or connected to the right side of the other extension blocks or units. Up to eight special blocks can be connected to a single MPU in the numeric order of No. 0 to No. 7.

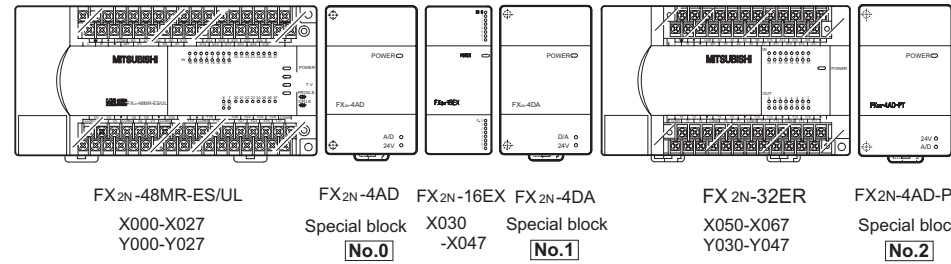

WIRING: The terminal layout shown below may differ from the actual layout. For the correct terminal layout, refer to section 2 External Dimensions and Parts.

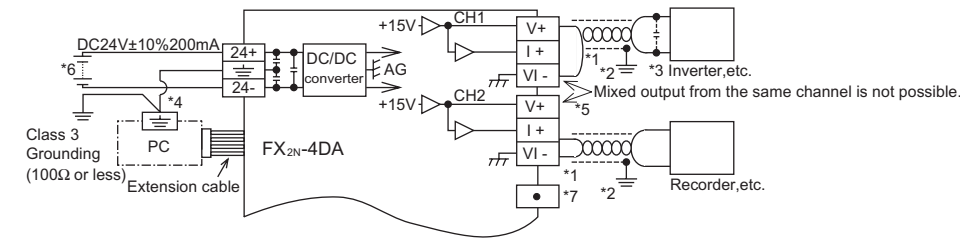

- Use a twisted pair shielded cable for the analog output. This cable should be wired away from power lines or any other lines which could induce noise.
- Apply 1-point grounding at the load side of the output cable (class 3 grounding: 100Ω or less).
- If electrical noise or a voltage ripple exists at the output, connect a smoothing capacitor of 0.1 to 0.47μF, 25V.
- Connect the terminal on the FX_{2N}-4DA with the terminal on the MPU of the programmable controller.
- Shorting the voltage output terminal or connecting the current output load to the voltage output terminal may damage the FX_{2N}-4DA.
- The 24V DC service power of the programmable controller can also be used.
- Do not connect any unit to the unused terminal.

4 SPECIFICATIONS

ENVIRONMENTAL SPECIFICATIONS

Item	Specification
Environmental specifications (excluding following)	Same as those for the FX _{2N} main unit
Dielectric withstand voltage	500V AC, 1min (between all terminals and ground)

PERFORMANCE SPECIFICATIONS

Item	Voltage output	Current output
Analog output range	-10V DC to +10V DC (External load resistance: 2kΩ to 1MΩ).	DC 0mA to +20mA (External load resistance: 500Ω).
Digital input	16 bits, binary, with sign (Effective bits for numeric value: 11 bits and sign bit (1 bit))	
Resolution	5mV (10V × 1/2000)	20μA (20mA × 1/1000)
Total accuracy	±1% (at full scale of +10V) ±1% (at full scale of +20mA)	
Conversion speed	2.1ms for 4 channels (Change in the number of channels used will not change the conversion speed.)	
Isolation	Photo-coupler isolation between analog and digital circuits. DC/DC converter isolation of power from FX _{2N} main unit. No isolation between analog channels.	
External power supply	24V DC ±10% 200mA	

Number of occupied I/O points 8 points taken from the FX_{2N} expansion bus (can be either inputs or outputs)

Power consumption 5V, 30mA (Internal power supply from MPU or powered extension unit)

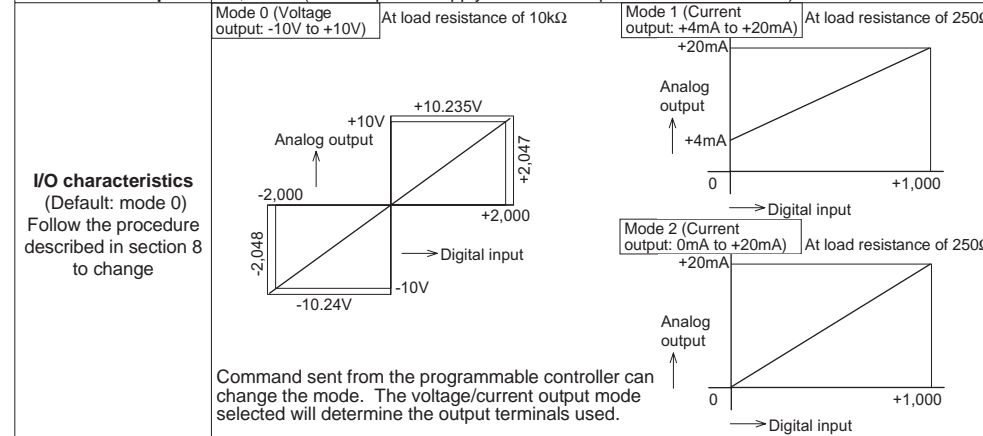

5 ALLOCATION OF BUFFER MEMORIES (BFM)

Data is transmitted between the FX_{2N}-4DA and the MPU via buffer memories (16-bit 32-point RAM).

BFM	Description
#0 E	Output mode select. Factory setting H0000
#1	Output data (Signed 16 bits binary: actual value 11 bits + sign) #1: CH1, #2: CH2, #3: CH3, #4: CH4
#2	
#3	
#4	
#5 E	Data holding mode. Factory setting H0000
#6, #7	Reserved

Buffer memories marked "W" can be written to using the TO instruction in the MPU.
The status of BFM #0, #5, and #21, (marked E) will be written to EEPROM, therefore the set values will be retained even after turning off the power.

- [BFM #0] Output mode select: The value of BFM #0 switches the analog output between voltage and current on each channel. It takes the form of a 4 digit hexadecimal number. The first digit will be the command for channel 1 (CH1), and the second digit for channel 2 (CH2) etc. The numeric values of these four digits respectively represent the following items:

H ○ ○ ○ ○
CH4 CH3 CH2 CH1
O = 0: Sets the voltage output mode (-10 V to +10 V).
O = 1: Sets the current output mode (+4 mA to 20 mA).
O = 2: Sets the current output mode (0 mA to +20 mA).

Switching the output mode resets the I/O characteristics to the factory-set characteristics. Refer to the performance specifications described in section 4.

Example: H2110 CH1 : Voltage output (-10 V to +10 V)
CH2 and CH3 : Current output (+4 mA to +20 mA)
CH4 : Current output (0 mA to +20 mA)

- [BFM #1, #2, #3 and #4]: Output data channels CH1, CH2, CH3, and CH4
BFM #1: Output data of CH1 (Initial value: 0) BFM #2: Output data of CH2 (Initial value: 0)
BFM #3: Output data of CH3 (Initial value: 0) BFM #4: Output data of CH4 (Initial value: 0)

- [BFM #5]: Data holding mode: While the programmable controller is in the STOP mode, the last output value in the RUN mode will be held. To reset the value to the offset value, write the hexadecimal value in BFM #5 as follows:

H ○ ○ ○ ○
CH4 CH3 CH2 CH1
O = 0: Holds the output.
O = 1: Resets to the offset value.

Example: H0011 CH1 and CH2 = Offset value CH3 and CH4 = Output holding

In addition to the above functions, the buffer memories can adjust the I/O characteristics of the FX_{2N}-4DA, and report the status of the FX_{2N}-4DA to the programmable controller.

BFM	Description
#8(E)	Offset/gain setting command CH1, CH2 Initial value H0000
#9(E)	Offset/gain setting command CH3, CH4 Initial value H0000
#10	Offset data CH1 *1
#11	Gain data CH1 *2
#12	Offset data CH2 *1
#13	Gain data CH2 *2
#14	Offset data CH3 *1
#15	Gain data CH3 *2
#16	Offset data CH4 *1
#17	Gain data CH4 *2
#18, #19	Reserved
#20(E)	Initialize. initial value = 0
#21 E	I/O characteristics adjustment inhibit (Initial value 1)
#22-#28	Reserved
#29	Error status
#30	K3020 identification code
#31	Reserved

Buffer memories marked "W" can be written to using the TO instruction in the MPU.
The status of BFM #0, #5, and #21, (marked E) will be written to EEPROM, therefore the set values will be retained even after turning off the power.

*1: Offset data: Actual analog output value when corresponding output data (BFM #1 through #4) is 0
*2: Gain data: Actual analog output value when corresponding output data (BFM #1 through #4) is +1,000

*3: When current output mode 1 (+4 mA to +20 mA) is set, the offset data will be automatically set to +4,000 and the gain data to +20,000. When the current output mode 2 (0 mA to +20 mA) is set, the offset data will be automatically set to 0 and the gain data to +20,000.

- [BFM #8 and #9] Offset/gain setting command: Changes offset and gain values of channels CH1 through CH4 by writing 1 to the corresponding Hex digits of BFM #8 or #9. The current values will be valid until this command is output.

BFM #8 BFM #9
H ○ ○ ○ ○ H ○ ○ ○ ○
G2 O2 G1 O1 G4 O4 G3 O3
O = 0: No changes done.
O = 1: Change data value.
(Program example : see section 8.)

- [BFM #10 through #17] Offset/gain data: The offset and gain values are changed by writing new data to BFM #10 through #17. The units of the data to be written is mV or μA. The data should be written and then BFM #8 and #9 set. Note that the data value will be rounded down to the nearest 5mV or 20μA.
- [BFM #20] Initialize: When K1 is written in BFM #20, all values will be initialized to the factory-settings. (Note that the BFM #20 data will override the BFM #21 data.) This initialize function is convenient if you have an error in adjustment.
- [BFM #21] I/O characteristics adjustment inhibit: Setting BFM #21 to 2 inhibits the user from inadvertent adjustment of I/O characteristics. The adjustment inhibit function, once set, will be valid until the Permit command (BFM #21=1) is set. The initial value is 1 (Permit). The set value will be retained even after power-off.

⑧ [BFM #29] Error status: When an error occurs, use the FROM command to read out the details of the error.

Bit	Name	Status when bit is set to "1" (turned on)	Status when bit is set to "0" (turned off)
b0	Error	Error if any of b1 through b4 is turned on	No error
b1	O/G error	Offset/gain data in EEPROM is abnormal or a data setting error occurs.	Offset/Gain data normal
b2	Power supply error	24V DC power failure	Power supplied normally
b3	Hardware error	Defective D/A converter or other hardware	Non-detective hardware
b10	Range error	The digital input or analog output value is out of the specified range.	The input or output value is in the specified range.
b12	G/O-Adjustment prohibit status	BFM #21 is not set to "1".	Adjustable status (BFM #21 = 1)

Bits b4 through b9, b11, b13 through b15 are not defined.

⑨ [BFM #30] The identification code for a special block is read using the FROM command. The identification code for the FX_{2N}-4DA unit is K3020. The MPU can use this facility in the program to identify the special block before commencing any data transfer from and to the special block.

Note : BFM #'s marked E/(E).

• Values of BFM #0, #5, and #21, (marked E) are stored in EEPROM memory of the FX_{2N}-4DA. BFM #10 to #17 are copied to EEPROM when the gain/offset setting command BFM #8, #9 is used. Also, BFM #20 causes resetting of the EEPROM memory. The EEPROM has a life of about 10,000 cycles (changes), so do not use programs which frequently change these BFMs.

• A mode change of BFM #0 automatically involves a change of the corresponding offset and gain values. Because of the time needed to write the new values to the internal EEPROM memory, a delay of 3 s is required between instructions changing BFM #0 and instructions writing to the corresponding BFM #10 through BFM #17.

Therefore, a delay timer should be used before writing to BFM #10 through #17.

6 OPERATION AND PROGRAM EXAMPLES

If the factory-set I/O characteristics are not changed and the status information is not used, you can operate the FX_{2N}-4DA using the following simple program. For the FROM and TO commands, refer to the FX Programming Manual.

CH1 and CH2: Voltage output mode (-10 V to +10 V)
CH3: Current output mode (+4 mA to +20 mA)
CH4: Current output mode (0 mA to +20 mA)

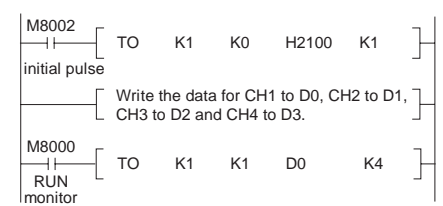

(H2100) → BFM #0
CH1 and CH2: Voltage output CH3: Current output (+4mA to +20 mA) CH4: Current output (0 mA to +20 mA)
Write data in respective data registers while observing the following ranges:
Data register D0 and D1: -2,000 to +2,000 Data registers D2 and D3: 0 to +1,000
Data register D0 → BFM #1 (output to CH1)
Data register D1 → BFM #2 (output to CH2)
Data register D2 → BFM #3 (output to CH3)
Data register D3 → BFM #4 (output to CH4)

Operation procedure

- Turn off the power of the MPU, and then connect the FX_{2N}-4DA. After that, wire the I/O lines of the FX_{2N}-4DA.
- Set the MPU to STOP, and turn on the power. Write the above program then switch the MPU to RUN.
- Analog values will be sent from D0 (BFM #1), D1 (BFM #2), D2 (BFM #3), and D3 (BFM #4) to the respective output channels of the FX_{2N}-4DA. When the MPU is in STOP, the analog values set before stopping the MPU will remain output. (The output will be held.)
- When the MPU is in STOP, the offset values can also be output. For a detailed description, refer to Section 5, ③.

Program example

For the following program, CH1 and CH2 of the FX_{2N}-4DA connected at special block position No. 1 are used as voltage output channels, CH3 as a current output channel (+4 mA to +20 mA), and CH4 as a current output channel (0 mA to +20 mA). When the MPU is in STOP, the output will be held. In addition, the status information is used.

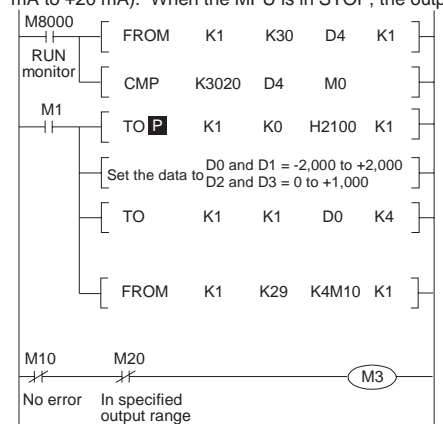

BFM #30 data (model code) of block No. 1 Transferred to data register D4.
M1 will be turned on when the model code is set to K3020 (FX_{2N}-4DA).
H2100 → BFM #0 (unit No.1)
CH1 and CH2: Voltage output CH3: Current output (+4 mA to +20 mA) CH4: Current output (0 mA to +20 mA)
D0 → BFM #1 (CH1 output)
D1 → BFM #2 (CH2 output)
D2 → BFM #3 (CH3 output)
D3 → BFM #4 (CH4 output)
BFM #29 (b15 to b0) → (M25 to M10)
Reads out the status data.

Output data abnormal

7 CAUTION REGARDING OPERATION

- Check whether the output wiring and/or expansion cables are properly connected on FX_{2N}-4DA analog special function block.
- Check that the FX_{2N} system configuration rules have not been broken, i.e. the number of blocks does not exceed 8 and the total system I/O is equal or less than 256 I/O.
- Ensure that the correct output mode has been selected for the application.
- Check that there is no power overload on either the 5V or 24V power source, remember the loading on the FX_{2N} MPU or a powered extension unit varies according to the number of extension blocks or special function blocks connected.
- Put the main processing unit into RUN.
- After turning on or off the 24 VDC power for analog signals, the analog output may fluctuate for approximately 1 second. This is due to time delays in the power supply from the MPU or differences in start time. For this reason, be sure to take preventive measures so that this output fluctuation will not affect the external units.

[Example of preventive measure]

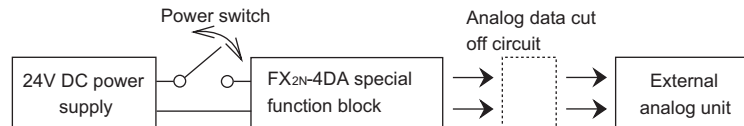

8 ADJUSTMENT OF I/O CHARACTERISTICS

I/O characteristics

The standard characteristics (factory default) are shown by the solid lines in the figure below. These characteristics can be adjusted according to the conditions of the user's system.

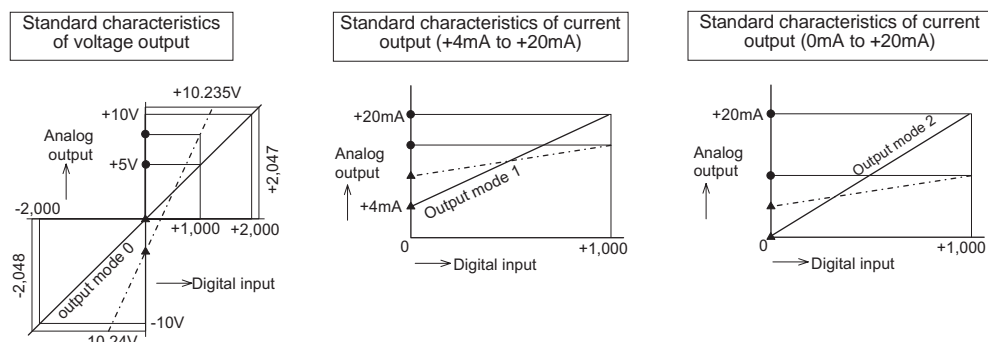

- . . . Gain value : Analog output value when the digital input is +1,000
- ▲ . . . Offset value : Analog output value when the digital input is 0

When the slope of the I/O characteristic line is steep: Slight changes to the digital input will greatly increase or reduce the analog output.

When the slope of the I/O characteristic line is gentle: Slight changes to the digital input will not always change the analog output.

Note that the resolution (minimum possible change of analog output) of the FX_{2N}-4DA is fixed.

Adjustment of I/O Characteristics

To adjust the I/O characteristics, set the offset and gain of the FX_{2N}-4DA either using push button switches connected to input terminals of the programmable controller or using the forced on/off function of a programming panel. To change the offset and gain, just change the conversion constants of the FX_{2N}-4DA. Metering of the analog output is not needed for adjustment, however a program should be created in the MPU.

An example program for adjustment is shown below. The example shows that for channel CH2 of FX_{2N}-4DA block No. 1, the offset value is changed to 7 mA, and the gain value to 20 mA. Note that for CH1, CH3, and CH4, the standard voltage output characteristics are set.

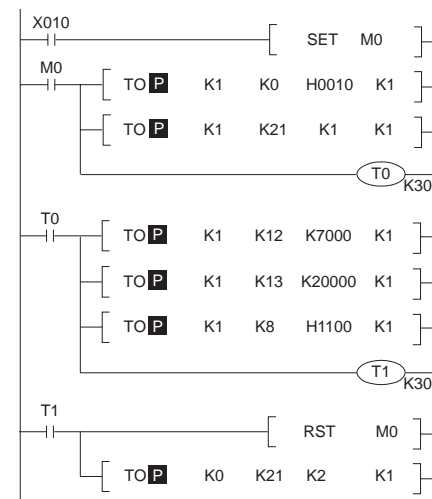

OPERATION START

(H0010)→BFM#0 Sets the mode of the output channel.
(K1)→BFM#21 Permits adjustment of I/O characteristics.

(K7000)→BFM#12 Sets the offset data. (Offset value: 7 mA)
(K20000)→BFM#13 Sets the gain data. (Gain value: 20 mA)
(H1100)→BFM#8 CH2 offset/gain setting command

OPERATION END

(K2)→BFM#21 Inhibits adjustment of I/O characteristics

After adjustment, the I/O characteristics will be as follows

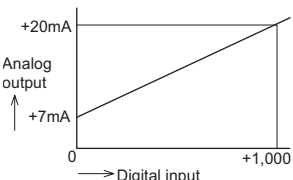

Outline of FROM and TO commands: For a detailed description, refer to the FX Programming Manual.

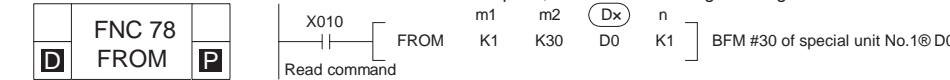

Read BFM

m1 : Special unit or block number (K0 to K7, numbered from the MPU)

m2 : Buffer memory head address (K0 to K31)

(D) : Head device number of destination data. T, C, D, KnM, KnY, KnS, V, and Z can be used to designate the head device. Each device number can be qualified using an index.

n : Number of transfer points (K1 to K32) (K1 to K16 for 32-bit command)

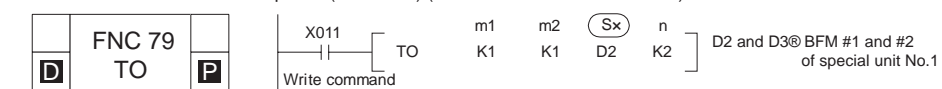

Write BFM

m1,m2,n : Same as above

(S) : Head device number of source data. T, C, D, KnX, KnM, KnY, KnS, V, Z, K, and H can be used to designate the head device. Each device number can be qualified using an index.

- When X010 and X011 are off, transfer will not be executed, therefore the destination data value will not be changed.

9 TROUBLESHOOTING

If the FX_{2N}-4DA does not operate properly, check the following items

- Check the external wiring. Refer to section 3 of this manual.
- Check status of the POWER indicator lamp (LED) of the FX_{2N}-4DA.
On : The extension cable is properly connected.
Off or flash : Check connection of extension cable. Also check the 5 V power supply capacity.
- Check status of the 24 V power indicator lamp (LED) of the FX_{2N}-4DA.
On : 24 VDC is supplied.
Off : Supply 24 VDC (+10%) to the FX_{2N}-4DA.
- Check the status of the D/A conversion indicator lamp (LED) of the FX_{2N}-4DA.
Flash : D/A conversion is normal.
On or off : The ambient conditions are not suitable for the FX_{2N}-4DA, or the FX_{2N}-4DA is defective.
- Check that the external load resistance connected to each analog output terminal does not exceed the capacity of the FX_{2N}-4DA drive (voltage output: 2kΩ to 1 MΩ / current output: 500Ω).
- Check the output voltage or current value using a voltmeter or ammeter, and confirm that the output meets the I/O characteristics. If the output does not meet the I/O characteristics, adjust the offset and gain again. Refer to section 8.

Note

To test the withstand voltage of the FX_{2N}-4DA, connect all the terminals to the grounding terminal.

Guidelines for the safety of the user and protection of the FX_{2N}-4DA special function block

- This manual has been written to be used by trained and competent personnel. This is defined by the European directives for machinery, low voltage and EMC.
- If in doubt at any stage during the installation of the FX_{2N}-4DA always consult a professional electrical engineer who is qualified and trained to the local and national standards. If in doubt about the operation or use of the FX_{2N}-4DA please consult the nearest Mitsubishi Electric distributor.
- Under no circumstances will Mitsubishi Electric be liable or responsible for any consequential damage that may arise as a result of the installation or use of this equipment.
- All examples and diagrams shown in this manual are intended only as an aid to understanding the text, not to guarantee operation. Mitsubishi Electric will accept no responsibility for actual use of the product based on these illustrative examples.

Manual number : JY992D65901
Manual revision : A
Date : JUNE 1997

MITSUBISHI ELECTRIC CORPORATION
HEAD OFFICE: MITSUBISHI DENKI BLDG MARUNOUCHI TOKYO 100 TELEX: J24532 CABLE MELCO TOKYO
HIMEJI WORKS: 840, CHIYODA CHO, HIMEJI, JAPAN